



## PH-BSI-NSF-UCFS-0104G

### Product Description

These countertop pharmacy refrigerators are certified in accordance with the NSF/ANSI 456 Standard for Vaccine Storage. With this certification, units protect pharmaceuticals at optimal temperatures, preventing waste and allowing for peak delivery.

These glass door refrigerators utilize microprocessor controllers and feature temperature alarms, remote alarm contacts, and probe access ports with included probes. Units run on natural, hydrocarbon refrigerant for environmental health and energy efficiency.

### General Description and Application

Description	Single Glass Door Pharmacy/Vaccine Undercounter Refrigerator Freestanding Left Hinged
Operational environment	Indoor use only. Optimal operating range: +18°C to +26°C (+65°F to +78°F), <70% RH
Storage capacity	1 cu. ft. gross volume
Door	One swing glass door, self-closing, left hinged, non-reversible, magnetic sealed gasket, keyed lock
Shelves	Three shelves (two adjustable/one fixed) with guard rail on back
Mounting and Installation	Leveling legs. Note: 4" of clearance on all sides must be maintained for adequate ventilation
Interior lighting	Shielded, switched LED lighting, full coverage, balanced spectrum
Airflow management	Forced Air technology, patent pending
External probe access	Rear wall port (23/32") dia.
Insulation	Cabinet is foamed-in-place with EPA compliant high density urethane foam
Exterior materials	White powder coated steel
Access control	Pyxis®, Omnicell® and AcuDose RX® compatible
General warranty	Two (2) years parts and labor warranty, excluding display probe calibration
Compressor warranty	Five (5) years compressor warranty
Product Weight	66 lbs.
Shipping Weight	94 lbs.
Rated Amperage	0.9 A max
Power Plug/Power Cord	NEMA 5-15 plug, 8 to 10 ft typical, conforms to UL471 requirements, Vaccine storage power cord warning label
Facility Electrical Requirement	110-120V AC: 15 A (minimum)
Agency Listing and Certification	Certified in accordance with the NSF/ANSI 456 Standard for Vaccine Storage. UL, C-UL, ETL, C-ETL listed (either single or dual agency listings) and certified to UL471 standard, hydrocarbon refrigerant safety, Energy Star Certified
Included Accessories	Temperature monitor device (TMD) complies with the current CDC guidelines, with 3 years certification of calibration, "buffered" probe in the product simulated solution, min/max memory, field installable, and visual & audible temp alarm  Pharmacy refrigerator/freezer toolkit and temperature logs

### Refrigeration System

Compressor	Hermetic, high performance
Refrigerant	EPA SNAP compliant, R600a, Isobutane
Condenser	Tube and grid construction, fanless
Evaporator	Plate wall
Defrost	Cycle optimized, zero energy

### Performance

Uniformity <sup>1</sup> (Cabinet air)	+/- 1.5°C
Stability <sup>2</sup> (Cabinet air)	+/- 0.7°C
Maximum temperature variation	+/- 1.8°C
Temperature rise after 8 sec door openings	Temperature did not exceed 6.8°C at any probe for all required NSF/ANSI 456 testing protocols <sup>3</sup>
Recovery after 3 min door opening	All probes recover to under 8°C within 5.5 min.
Energy consumption	0.71 KWh/day <sup>4</sup>
Average heat rejection	1.01 KWh/day (144 BTU/h) <sup>4</sup>
Noise pressure level (dBA)	34 or less installed
Pull down time to nominal operating temp	35 min

### Controller, Configuration, Alarms and Monitoring

Controller technology	Parametric, microprocessor, LED display with 0.1°C resolution
Temperature setpoint range	1°C to 10°C (Setpoint must remain unaltered from the factory setting to remain compliant with NSF/ANSI 456 Standard for Vaccine Storage requirements)
Display probe	Calibrated, stainless steel
External alarm connection	State switching remote alarm contacts
Alarms	Visual and audible indicators High / Low temperature, compliant with alarm requirements defined in the NSF/ANSI 456 Standard for Vaccine Storage
Simulator ballast	Glass bead thermal media

Performance data acquired at 22°C ambient, using NSF/ANSI 456 compliant validation ballast probes, empty chamber, during stabilized steady state operation and a DAQ sampling rate of one measurement every 10 seconds

- 1 - Uniformity is defined as the maximum variance in temperature across all probes at any point in time over the testing period
- 2 - Stability is defined as the maximum variance in temperature experienced by any single probe over the testing period
- 3 - Temperature performance for all loaded and unloaded door opening protocols, all alarm, controller and probe requirements as defined in the NSF/ANSI 456 standard for vaccine storage
- 4 - Data per Energy Star test results or equivalent testing and calculation. Heat rejection based on daily averages, not continuous operation. Performance exceeds Energy Star requirements.

### Product Data Sheet

Countertop 1 cu. ft. Glass Door Freestanding Vaccine Refrigerator - Certified to NSF/ANSI 456 Standard for Vaccine Storage

### Certifications



\*-one or more of these certifications may apply to this unit.

### Temperature Probes

Probe	Ave	Min	Max
1	4.0	3.5	4.5
2	4.0	3.7	4.3
3	3.6	3.2	4.1
4	3.4	2.9	3.8
5	4.4	4.2	4.6
6	5.3	5.2	5.5
7	4.1	3.8	4.3
8	5.1	5.0	5.3
9	3.6	2.9	4.2
10	4.0	3.6	4.3
11	6.1	5.8	6.4
12	5.2	5.1	5.4
13	4.8	4.6	4.9
14	5.6	5.4	5.8
15	3.9	3.6	4.2

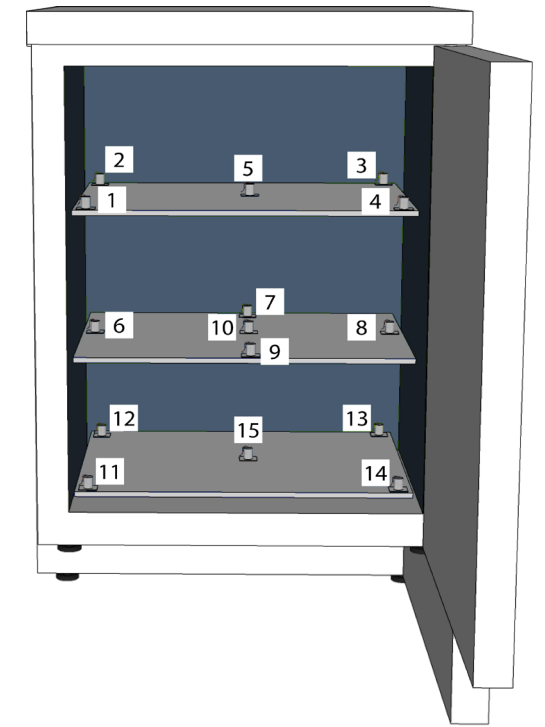

### Temperature Charts

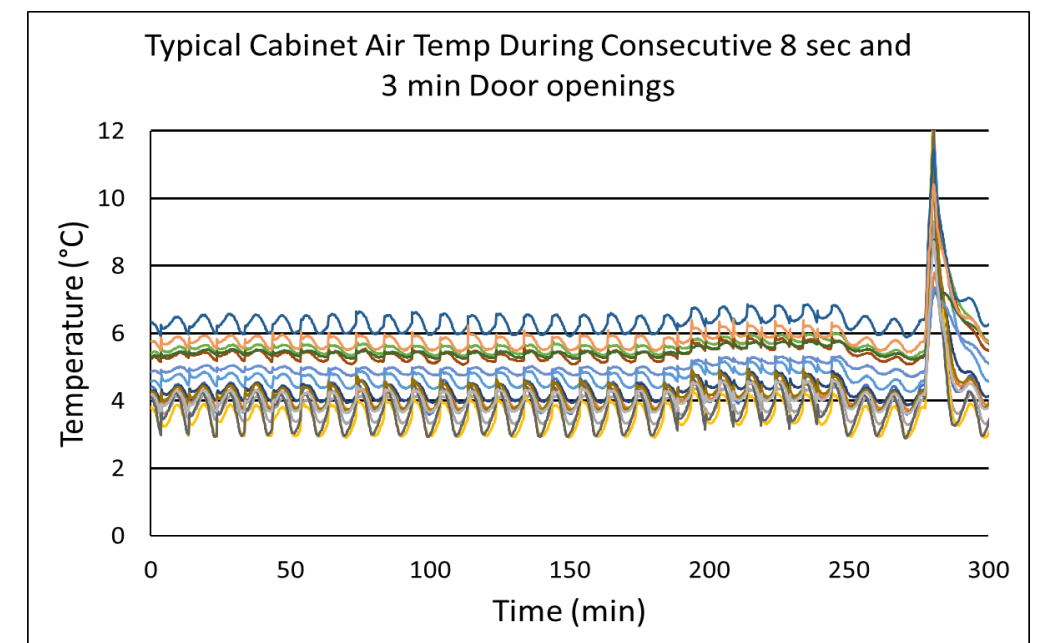
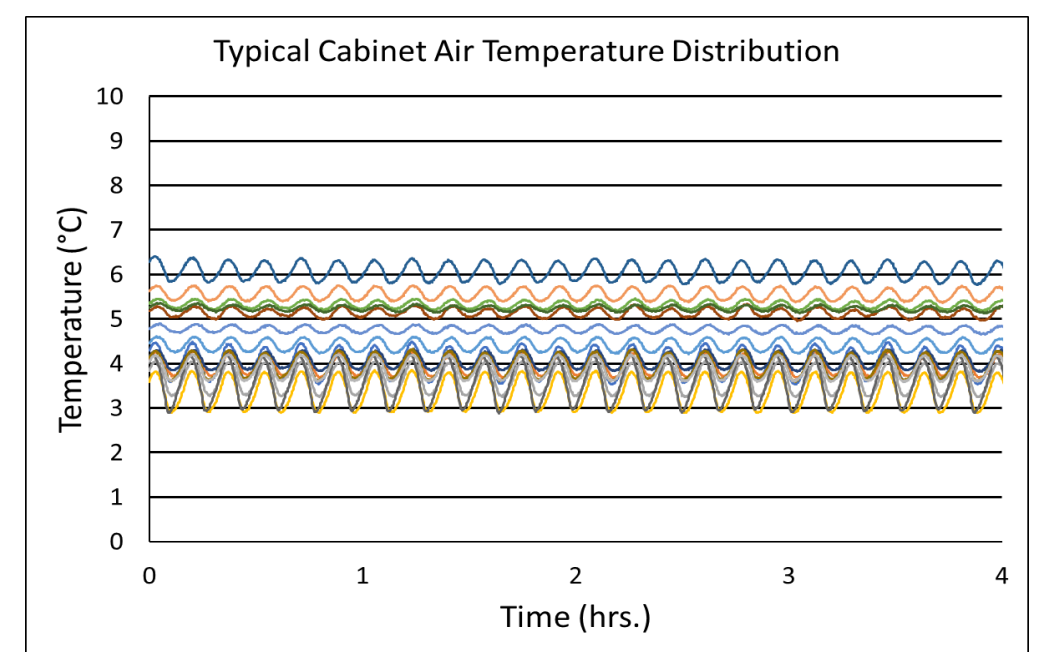
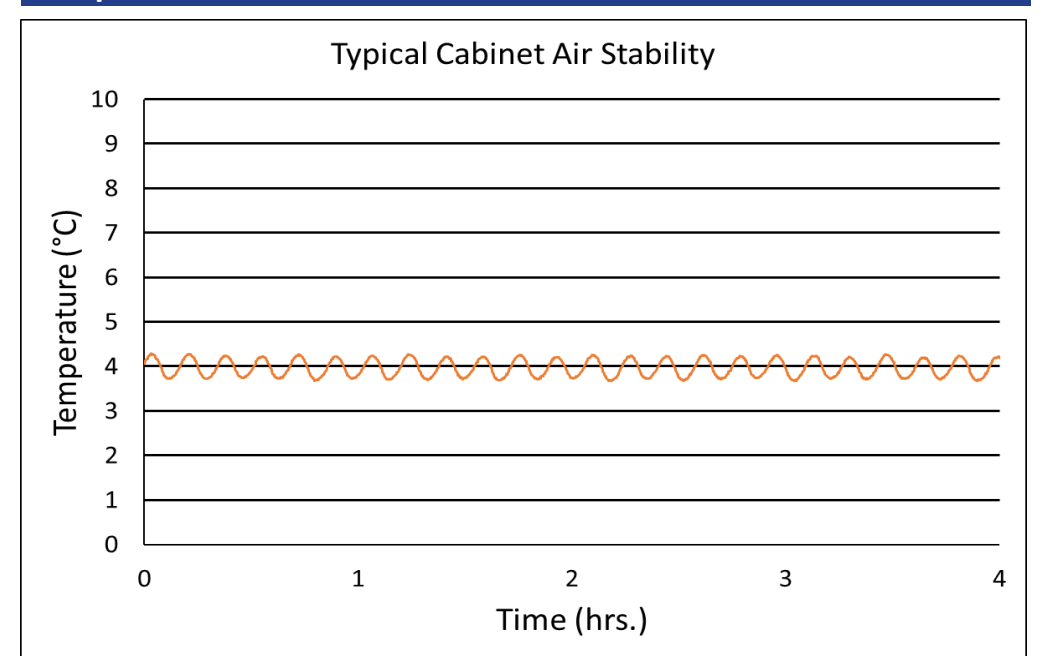



**Product Data Sheet**

Countertop 1 cu. ft. Glass Door Freestanding Vaccine Refrigerator - Certified to NSF/ANSI 456 Standard for Vaccine Storage

**Images**



**Dimensions**

	Width	Depth	Height	Door Swing	Total open Depth
Exterior	17 1/4"	19 1/4"	21 1/4"	16"	35 1/4"
Interior	14"	7 3/4"	12 1/8"		

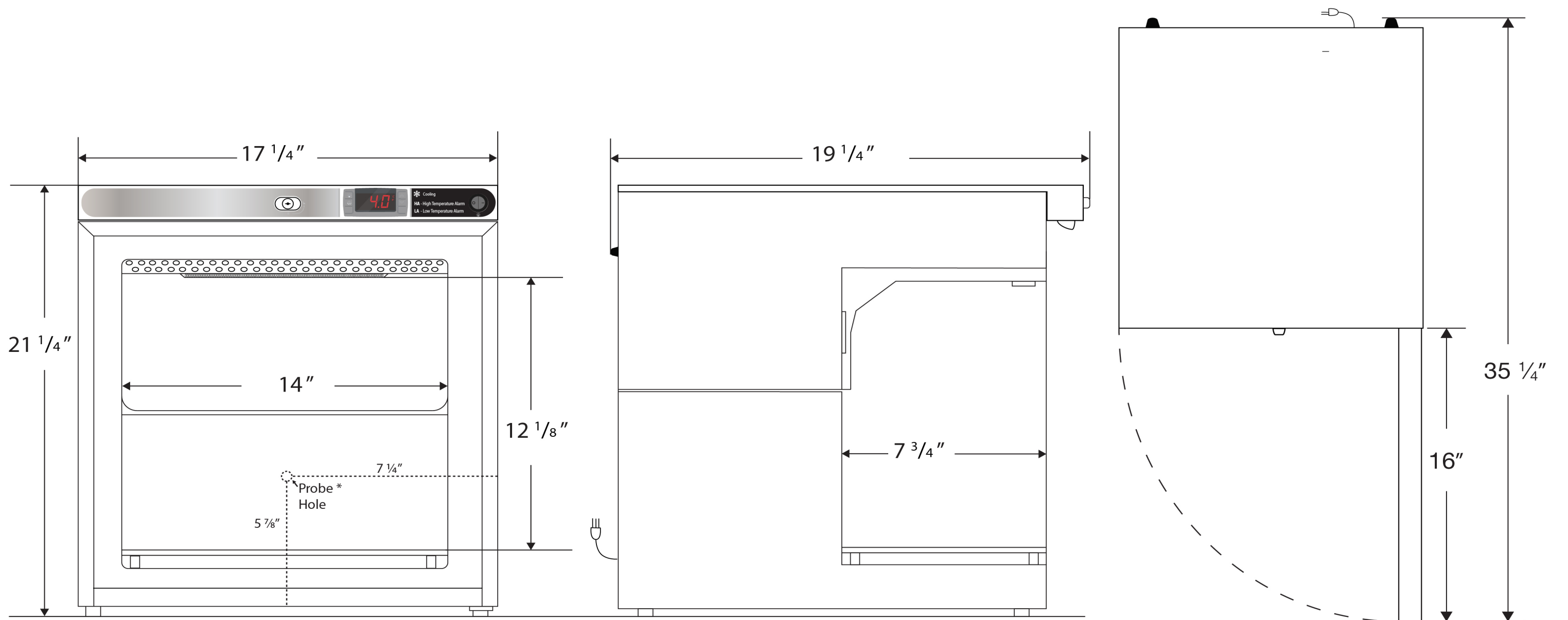

**Note:** This unit must have 4" clearance on sides and back for adequate ventilation

**Contact**

Phone 866-674-7220  
 Email [info@bsilab.com](mailto:info@bsilab.com)  
 Rev\_10042022