

## M1-SBFF-1FM SMARTBOX® Chamber System

## SMARTBOX®

The M1-SBFF-1FM automates a three-stage euthanasia cycle at the push of a button: charging, dwell time, and exhaust. At start of cycle, doors automatically lock and will not unlock until CO<sub>2</sub> evacuation is complete. The clear polycarbonate doors provide visibility while the front-loading, swing-down design offers easy cage access. Airtight, gasket-sealed doors prevent gas leakage during operation. The manifold design ensures even gas distribution. The system accommodates the full range of rodent cages from all manufacturers.

### Compliant with AVMA Guidelines

- Accommodates 20 shoebox mouse cages or 4 standard rat cages
- After starting system, technician is free to do other work
- Programs can be customized based on facility requirements
- Automation virtually eliminates operator error
- Electronically monitored safety system prevents operation when chamber door is not properly closed
- Doors automatically lock during operation and unlock after evacuation



Pre-Mounted Flow Meter Included

### Required Accessories (choose one):

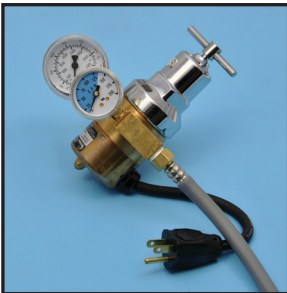

EA-285  
(use with cylinders)

OR



FF-1130  
(use with piped-in gas)

M1-SBFF-FM includes:

SMARTBOX® Side Control Box, M1 Chamber, Exhaust Blower, Flow Meter, 8' of 4" Exhaust Tubing, two 4" Hose Clamps

### Optional Accessories



EA-1040



EA-1002

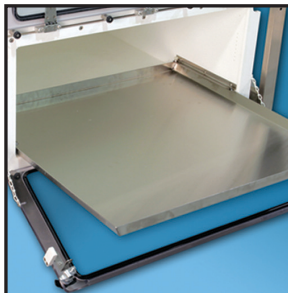

EA-5500



EZ-1336-C

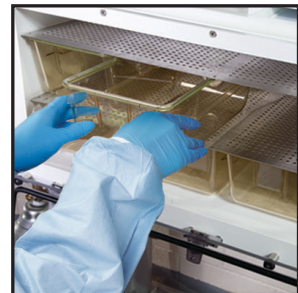

EA-1315

## SMARTBOX®

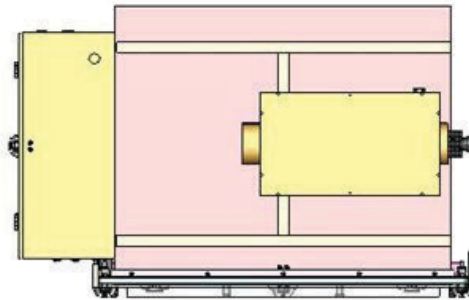

**TOP VIEW**

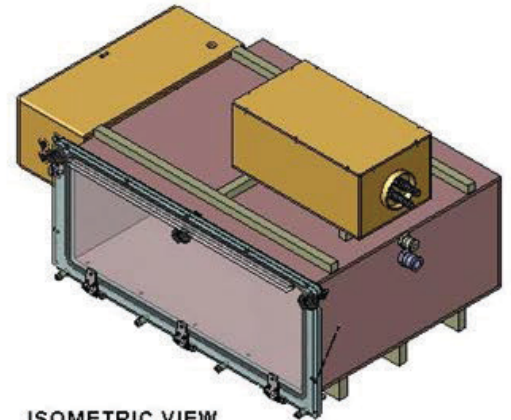

**ISOMETRIC VIEW**

Connects to 4" House Exhaust  
-Requires 80 cfm

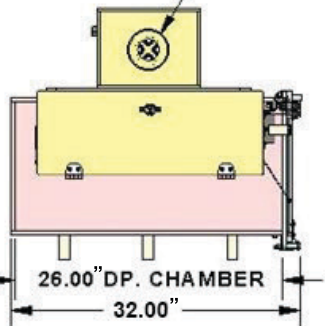

**LEFT SIDE VIEW**

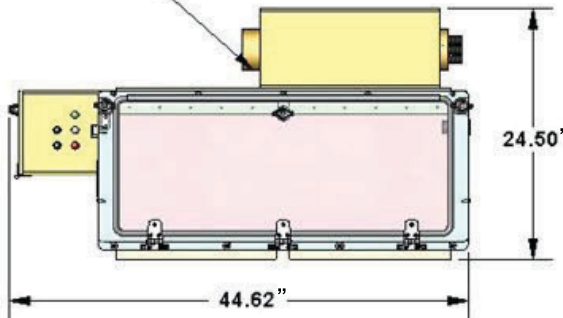

**FRONT VIEW**

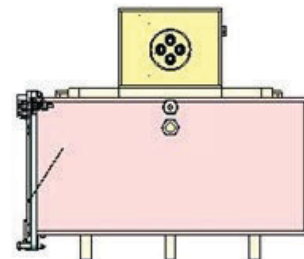

**RIGHT SIDE VIEW**

**INSIDE CHAMBER DIMENSIONS**

32.0" W X 30.5" D X 12.5" H

**M1-SBFF-1 SMARTBOX CHAMBER SYSTEM**

**REQUIREMENTS**

ELECTRIC	120V 5 AMP
FLOW RATE	50 LPM OF CO2
4" DUCT	80 CFM