

ULTIMA series 1600 LXP  
INSTALLATION MANUAL





## CONTENTS

<b><u>GENERAL INFORMATION</u></b>	<b>5</b>
INTRODUCTION TO THE INSTALLATION INSTRUCTIONS	5
COPYRIGHT	5
PRODUCT LIABILITY	5
SYMBOLS	5
<b><u>SHIPPING PACKAGE AND HANDLING</u></b>	<b>6</b>
PACKING	6
TRANSPORT	6
HANDLING	6
STORAGE	6
<b><u>CONDITIONS OF USE / ENVIRONMENT</u></b>	<b>7</b>
OPERATING ENVIRONMENT	7
AFTER INSTALLATION, MAKE SURE :	7
SAFETY SYMBOLS	7
<b><u>UNPACKAGING AND SETTING IN PLACE</u></b>	<b>8</b>
<b><u>CHARACTERISTICS</u></b>	<b>9</b>
WASHER DIMENSIONS STD	9
<b><u>HYDRAULIC CONNECTIONS</u></b>	<b>10</b>
WATER CONNECTIONS	10
<b><u>WATERS LOCATION</u></b>	<b>12</b>
<b><u>ELECTRICAL CONNECTION</u></b>	<b>13</b>
<b><u>DISCONNECT SWITCH LOCATION</u></b>	<b>14</b>
<b><u>DISCHARGE OF WASTE WATERS</u></b>	<b>15</b>
<b><u>DISCHARGE OF EXHAUST VAPOR</u></b>	<b>16</b>
<b><u>CONNECTIONS ON THE WASHER</u></b>	<b>17</b>
WATERS	17
DRAIN	18
ELECTRICAL	18

---

<b>WASHING PRODUCTS</b>	<b>18</b>
LANCER LCD DETERGENT	18
LANCER LCA NEUTRALISANT	19
<b>INSTALLATION OF THE WASHING PRODUCTS</b>	<b>20</b>
<b>PRECAUTIONS BEFORE USING YOUR WASHER</b>	<b>21</b>

## GENERAL INFORMATION

### INTRODUCTION TO THE INSTALLATION INSTRUCTIONS

These instructions are provided to help you with your electrical wiring and plumbing installation prior to receiving your washer. Follow them closely, they have been written with your best interests in mind.

This document also indicates the dimensions of the washer so that you can check the access to the area where the machine will be installed.

### COPYRIGHT

All rights reserved.

GETINGE LANCER pays close attention to all technical developments and continuously seeks to improve its products and services in order to provide an adequate response to the needs of its clients. GETINGE LANCER therefore reserves the right to modify its documentation without prior notice.

### PRODUCT LIABILITY

This washer must be used under normal operating conditions as indicated in the GETINGE LANCER user manual supplied with the machine.

Failure to follow these recommendations may result in material damage or personal injury and will render null and void any warranty or liability on GETINGE LANCER part.

Liability will not be accepted in the event of incorrect use or modification of the washer without the prior agreement of GETINGE LANCER.

### SYMBOLS

This manual contains some extremely important warnings, instructions and notices, so the following symbols have been used to draw your attention to them.



SAFETY WARNING FOR PERSONS AND EQUIPMENT



ELECTRICAL DANGER

## SHIPPING PACKAGE AND HANDLING

### PACKING

*Applicable only to washers delivered in GETINGE LANCER supplied packaging.*

Packing of a washer-dryer consists of a cardboard box and a wooden pallet.

The washer is wrapped with a plastic film, bolted to the pallet, and covered with a cardboard box.

### TRANSPORT

Transport indicators :

- Label « FRAGILE »
- Label « HAUT AND BAS »- « UP AND DOWN »

For machines transported by air or by sea, packaging has a tilt indicator (« TIP AND TELL ») that provides a visual indication if the machine has not remained upright during transit.

### HANDLING



DO NOT USE A FORKLIFT TO PUSH THE PACKAGE

USE A FORK LIFT OR PALLET JACK TO MOVE THE WASHER



BEFORE MOVING THE WASHER, CHECK THAT THE FORK LIFT AND/OR PALLET JACK ARE CAPABLE OF RAISING THE LOAD (THE WEIGHT IS WRITTEN ON THE PACKAGE OR THE SHIPPING DOCUMENTATION).

### STORAGE

The washer-dryer must be stocked in a dry, sheltered area whose room temperature will not be lower than 0°C (32°F) and not exceed 50°C (122°F).



IF THE WASHER-DRYER IS NOT USED FOR A PERIOD OF 3 WEEKS OR MORE, IT IS RECOMMENDED TO REMOVE THE CHEMICAL CONTAINERS AND FLUSH THE CHEMICAL LINES WITH WATER. CONTACT GETINGE LANCER FOR ASSISTANCE.

## CONDITIONS OF USE / ENVIRONMENT

### OPERATING ENVIRONMENT

The washer is designed to be used in the following operating environment:

- an indoor environment.
- at a maximum elevation of 2,000 meters (6,562 ft).
- at temperatures between 5°C and 40°C (41°F and 104°F).
- at a maximum of relative humidity of 80% up to 31°C (88°F) with a linear drop of 50% at 40°C (104°F).
- mains voltage fluctuations must not be greater than  $\pm 10\%$  of the rated voltage.
- normal level of transient overvoltages in the mains supply: category II of IEC 60364-4-443.

### AFTER INSTALLATION, MAKE SURE :

- all parts have been installed as per the installation instructions
- all screws have been fully tightened.
- the parts have no sharp edges that could injure users.
- all hoses, pipes, and connections are complete and fault-free.
- all of the device's features are operating correctly. Adjust them as required.

### SAFETY SYMBOLS



Mandatory use of safety glasses or goggles



Mandatory use of safety gloves

## UNPACKAGING AND SETTING IN PLACE



THIS MACHINE MUST BE INSTALLED AND USED ACCORDING TO THE INSTRUCTIONS CONTAINED WITHIN THIS DOCUMENT. INCORRECT INSTALLATION OR USAGE MAY CAUSE THE PROTECTION PROVIDED BY THIS EQUIPMENT TO BE IMPAIRED.



A TRAINED GETINGE LANCER SERVICE TECHNICIAN SHOULD PERFORM THE FIRST TIME START-UP.

- Remove the box and the plastic film from around the washer.
- Move the washer to dedicated area.
- Remove the leveling feet, hoses and manuals from the wash chamber or in the chemical drawer.
- Level the washer by adjusting the height adjustable feet.

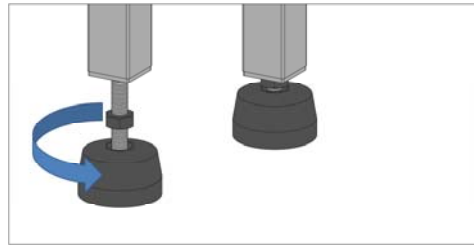

### Installation area

The washer-dryer must be installed in the room allow sufficient space for easy replacement and periodic inspections

**Minimum distance of 460mm (18.11")**

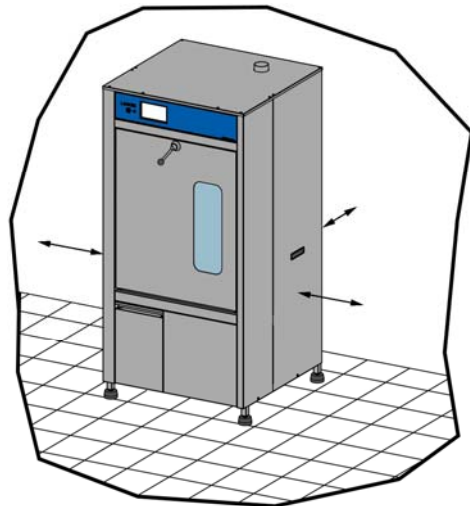



# CHARACTERISTICS

Heat loss : 5950 Kcal/h (1500 BTU/h)

Noise level : 69 dBA according to Machinery Directive 2006/42/EC

## WASHER DIMENSIONS STD

### Overall dimensions

Height 1814 mm (71.41")  
 Width 866 mm (34.09")  
 Depth 858 mm (33.78")

Weight 215kg (474 lbs)

### Chamber dimensions

Height 858 mm (33.77")  
 Width 703 mm (27.67")  
 Depth 678 mm (26.69")

Dimensions tolerances : +/- 5mm (+/- 0.2")

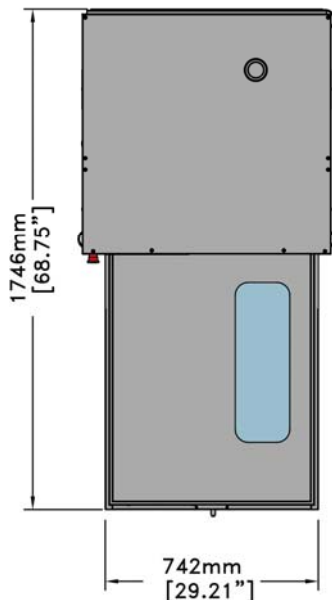
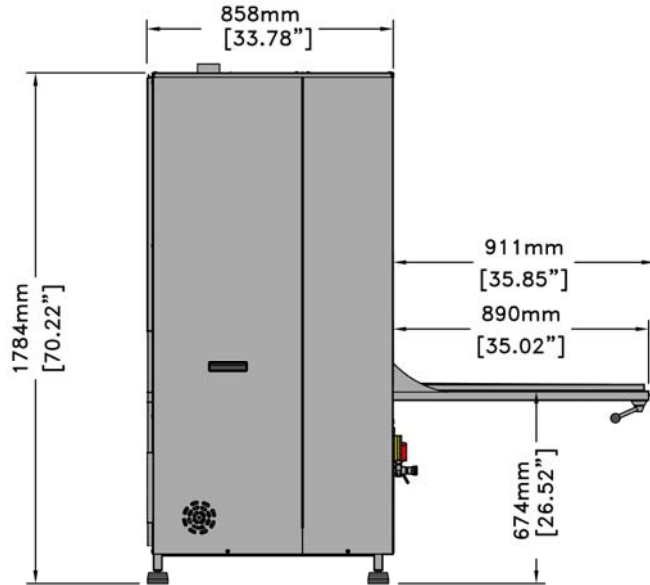
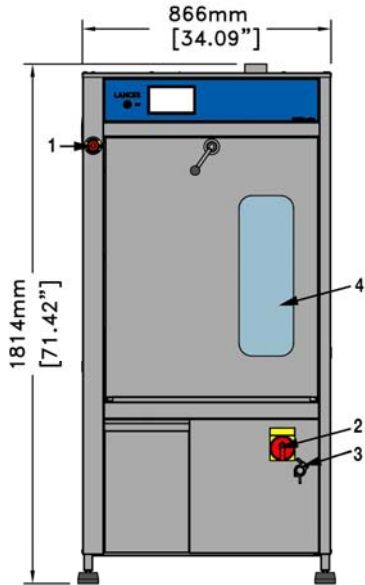

- 1 - EMERGENCY STOP BUTTON OPTION 90010454
- 2 - MAIN POWER ON/OFF SWITCH OPTION 90010455
- 3 - SAMPLING SYSTEM OPTION 90010532
- 4 - GLASS DOOR OPTION 90010637

## HYDRAULIC CONNECTIONS

### WATER CONNECTIONS

Flush water supply lines prior to connecting to the washer. Turn off water supply valves and drain the water supply hoses.

The water supply hoses required to connect the washer to the various water inlets are provided with the machine.

The maximum length of all connecting lines is 2,000mm (78.73") and a color-code identification label is attached to each water supply hose.

The cold and hot water inlets are equipped with thread size adapters which must be connected to the water supply.

Make the connections by fitting the strainer filters between the thread size adapter and the threaded connection at the water supply hose.

- 1- STRAINER FILTER
- 2- THREAD SIZE ADAPTER
- 3- CONNECTING Y (*IF NECESSARY*)

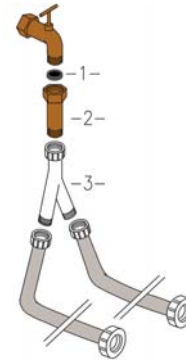

All connection are made on the back of the washer and are marked with identification labels.

In order to help you during the hydraulic connections of your washer/dryer, you will find in sections hereafter, the different colors of labels present on different connecting hoses and connecting fittings located on the bodywork of the washer/dryer.

The water supply valves must be located within the area shown on the drawing on page 12.

**COLD WATER :**



*STANDARD*

A valve with a male threaded nozzle, 20/27 diameter, (3/4" hose thread) is required.

Flow rate :	20 l/mn (5.3GPM) mini.
Pressure :	200 kPa (2 bars or 29 PSI) mini. and 600 kPa (6 bars or 87 PSI) maxi.
Temperature :	10°C - 25°C (50 °F - 77°F)
pH :	6.5 - 9
Hardness :	25 °f maxi.
	14 °d maxi.
	14 gpg maxi
	250 ppm maxi

**HOT WATER :**



*STANDARD*

A valve with a male threaded nozzle, 20/27 diameter, (3/4" hose thread) is required.

If there is no hot water supply, provide an additional cold water valve.

Flow rate :	20 l/mn (5.3GPM) mini.
Pressure :	200 kPa (2 bars or 29 PSI) mini. and 600 kPa (6 bars or 87 PSI) maxi.
Temperature :	10°C -50°C (50 °F - 122°F)
pH :	6.5 - 9
Hardness :	25 °f maxi.
	14 °d maxi.
	14 gpg maxi
	250 ppm maxi

**PURIFIED WATER :**



*STANDARD*

A valve with a threaded male nozzle, 20/27 diameter (3/4" hose thread) is required.

Flow rate :	20 l/mn (5.3GPM) mini.	
Pressure :	200 kPa (2 bars or 29 PSI) mini. and 600 kPa (6 bars or 87 PSI) maxi.	
Temperature :	10°C - 25°C (50 °F - 77°F)	
pH :	5 – 7.5	
Hardness :	4 °f < softened water < 8 °f	Purified water < 4 °f
	2 °d < softened water <4 °d	Purified water < 2 °d
	2 gpg < softened w. < 4 gpg	Purified water < 2 gpg
	40 ppm < softened w. < 80 ppm	Purified water < 40 ppm

## WATERS LOCATION

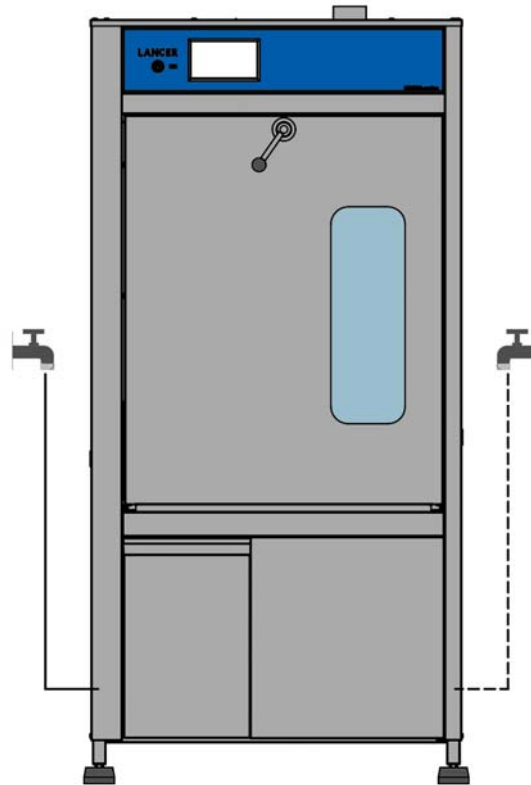

Maximum distance available  
1350 mm (53.15")

### WATERS

Maximum distance available  
680 mm (26.77")

WATERS MUST BE LOCATED IN THIS AREA.

Services can be installed to the left, to the right or behind the machine

**Only one connection point is required**



DO NOT BEND OR CONSTRICT THE TUBE AS THIS COULD STOP OR SLOW DOWN THE FLOW OF WATER.

CHECK THAT THE SCREWS AT BOTH ENDS OF THE TUBE ARE TIGHTENED CORRECTLY TO PREVENT WATER LEAKAGE.



ENSURE THAT THE MINIMUM CLEARANCE REQUIREMENT IS MAINTAINED BETWEEN THE WASHER AND UTILITY CONNECTION POINT.

## ELECTRICAL CONNECTION



BEFORE CARRYING OUT ANY WORK ON THE WASHER, MAKE SURE IT IS SWITCHED OFF AT THE ELECTRICAL DISCONNECT SWITCH.



**ELECTRICAL SUPPLY :**  
CHECK FOR CORRECT VOLTAGE SUPPLY AT THE ELECTRICAL PANEL BEFORE MAKING ANY ELECTRICAL CONNECTIONS.



BEFORE ANY TEST, CHECK THE ROTATION DIRECTION OF THE RECYCLING PUMP.



**ELECTRICAL SUPPLY CABLE CONNECTION AND ROUTING :**  
THE ELECTRICAL CONNECTION IS MADE AT THE SCREW-TYPE TERMINAL BLOCK LOCATED BEHIND THE LOWER FRONT PANEL OF THE MACHINE USING WIRE SUITABLE FOR AT LEAST 75°C. THE TERMINALS MUST BE SECURELY TIGHTENED TO THE POWER SUPPLY WIRES.  
THE POWER SUPPLY CABLE SHOULD ENTER THROUGH THE PANEL KNOCKOUT LOCATED ON THE UTILITY PLATE AT THE BACK OF THE WASHER.  
CARE MUST BE TAKEN TO PREVENT THE WIRE FROM CONTACTING ANY MOVING COMPONENTS WITHIN THE MACHINE.



**ELECTRICAL PROTECTION DEVICE :**  
A CIRCUIT BREAKER OR FUSES MUST PROVIDE PROTECTION FROM OVERCURRENT ELECTRICAL CONDITIONS. THE CIRCUIT BREAKER OR FUSES MUST BE LABELLED AS THE PROTECTION DEVICE FOR THE GETINGE LANCER WASHER. THE OVERCURRENT PROTECTIVE DEVICE SIZE REQUIRED FOR THIS MACHINE IS SPECIFIED BELOW OR MUST MEET LOCAL ELECTRICAL CODES.

*STD*

Total power to be supplied	Supply voltage	Consumption	Overcurrent protective device size
<b>21 kW</b>	<b>200-208V Tri +T / 60Hz</b>	<b>59 A / phase</b>	<b>70 A / phase</b>

## DISCONNECT SWITCH LOCATION

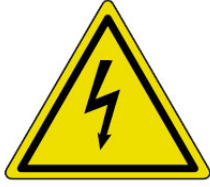

**ELECTRICAL DISCONNECT SWITCH :**

THE FOLLOWING EQUIPMENT MUST BE EASILY AND QUICKLY ACCESSIBLE NEAR THE WASHER : A DISCONNECTING SWITCH LOCKABLE IN THE OPEN (OFF) POSITION.



DURING THE INSTALLATION, YOU WILL SEE BLUE WIRES IN THE ELECTRICAL HARNESS. THESE WIRES ARE NOT APPROPRIATE TO THE UL / CSA STANDARDS AND CANNOT BE USED UNDER THESE LABELS.

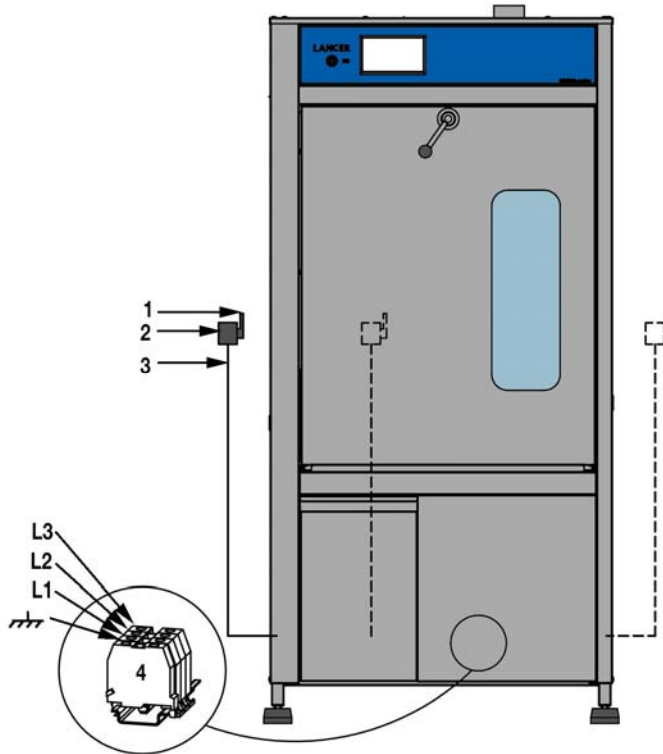

- 1 ELECTRICAL DISCONNECT SWITCH (PROVIDED BY OTHERS)
- 2 CIRCUIT BREAKER OR FUSES (PROVIDED BY OTHERS)
- 3 ELECTRICAL CABLE ( PROVIDED BY OTHERS)
- 4 TERMINAL BLOCK



ENSURE THAT THE MINIMUM CLEARANCE REQUIREMENT IS MAINTAINED BETWEEN THE WASHER AND UTILITY CONNECTION POINT.

# DISCHARGE OF WASTE WATERS

## DRAINING

Provide a rigid standpipe and plumbing trap with :

- Height above floor level : from 800 mm (31") minimum to 900 mm (35") maximum.
- Temperature up to 95°C (203°F).
- With inner tube Ø 40mm (1.6") and capable of accepting a flow of 40 l/min (10.6 GPM).

## OVERFLOW

Provide a rigid standpipe and plumbing trap with :

- Height above floor level : 500 mm (20") maximum.
- Temperature up to 95°C (203°F).
- With outside tube Ø 32mm (1.25") and capable of accepting a flow of 20 l/min (5.3 GPM).

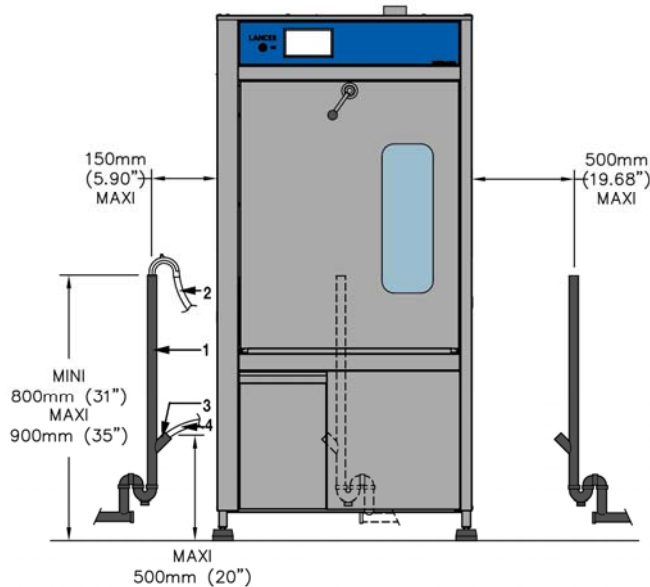

Maximum distance available  
600 mm (23")

Maximum distance available  
255 mm (10")

**THE DISCHARGE TUBE MUST BE LOACATED IN THIS AREA.**

The discharge tube can be installed to the left, to the right or behind the machine

**Only one connection point is required**



**DO NOT BEND OR CONSTRICT THE TUBE AS THIS COULD STOP OR SLOW DOWN THE FLOW OF WATER.**



**ENSURE THAT THE MINIMUM CLEARANCE REQUIREMENT IS MAINTAINED BETWEEN THE WASHER AND UTILITY CONNECTION POINT.**

## DISCHARGE OF EXHAUST VAPOR

The machine discharges hot moist air, causing condensation in the exhaust. Horizontal sections of exhaust ducting will require drains at the lowest points.

The machine is equipped with an exhaust fan.



**TO AVOID PRESSURE PROBLEMS IN THE CHAMBER, DO NOT BLOCK THE HOT MOIST AIR EXHAUST TUBE.**

**A DIRECT (HARD PIPE) CONNECTION BETWEEN THE WASHER'S EXHAUST TUBE AND BUILDING EXHAUST SYSTEM IS NOT ALLOWED FOR SAFETY REASONS.**

### STANDARD

Characteristics:

- Air flow : 120 m<sup>3</sup>/H (70 CFM).
- Maximum temperature : 95°C (203°F)
- Maximum relative humidity : 95%

Two solutions are available to extract hot moist air:

### EXTRACTION DIRECTLY INTO THE ROOM

The room must be well ventilated.

- 1- hot moist air exhaust tube



### EXTRACTION WITH AN EXHAUST HOOD

Provide, by others, an exhaust hood placed between 100mm (4 ") minimum and 1000mm (40") maximum above the washer exhaust tube.

- 1- hot moist air exhaust tube
- 2- exhaust hood

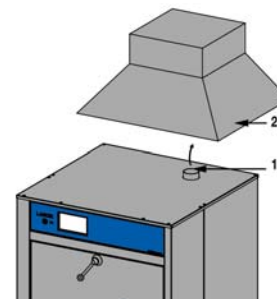



## CONNECTIONS ON THE WASHER

### WATERS

- 1 COLD WATER
- 2 HOT WATER
- 3 PURIFIED WATER
- 4 COMPRESSED AIR (IF NECESSARY - IN ACCORDANCE WITH OPTION SELECTED)
- 5 COLD WATER FOR CONDENSER OPTION (01060119) AND/OR COOLING DRAINING OPTION (90010447)

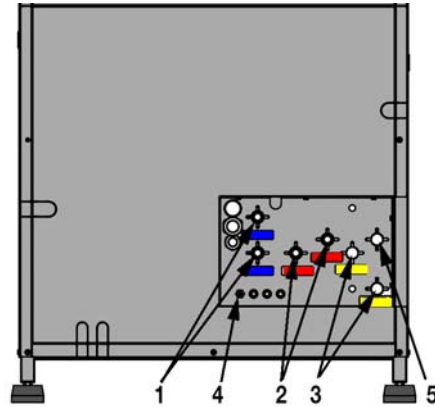

## DRAIN

- 1 WASTE WATER FLEXIBLE EMPTYING HOSE
- 2 FLEXIBLE OVERFLOW HOSE
- 3 FLEXIBLE OVERFLOW HOSE WITH CONDENSER OPTION (01060119) (REPLACE NUMBER 2)

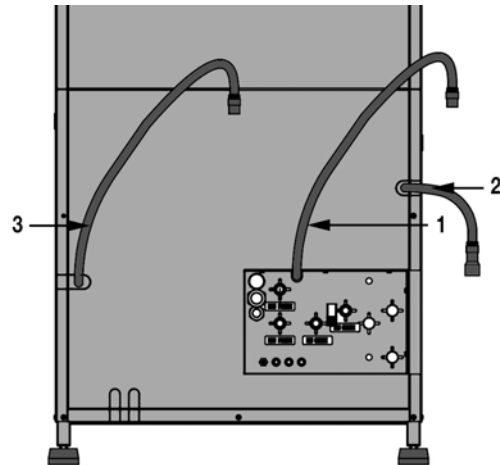

## ELECTRICAL

- 1 KNOCKOUT FOR ELECTRICAL CABLE 60 HZ
- 2 KNOCKOUT FOR ELECTRICAL CABLE 50HZ

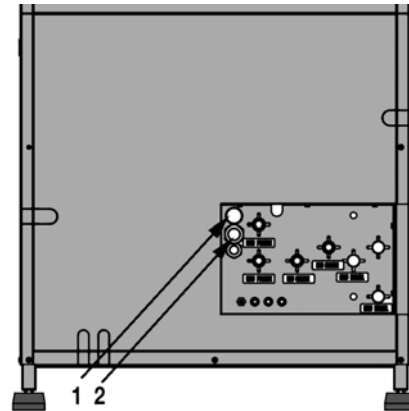

## WASHING PRODUCTS

The washing and operational performance of the washer has been validated with the GETINGE LANCER line of cleaning chemicals. The use of GETINGE LANCER cleaning chemicals guarantees good results and long life of your machine.

### LANCER LCD DETERGENT

LANCERCLEAN Detergents are available in three solutions:

#### LCD-P:

Our most popular detergent, LCD-P is a potassium hydroxide based solution.

LCD-P provides excellent cleaning results for all types of contaminants and standard laboratory soils and is recommended for use in all glassware washers.



**LCD-S:**

A sodium hydroxide based solution; LCD-S is specifically formulated to provide exceptional cleaning for the most difficult types of contaminants. LCD-S is used for petroleum applications, "baked-on" organic residues and other hard to clean soils that require a more powerful cleaning agent. LCD-S is recommended for use in all glassware washers.

**LCD-H:**

A low pH detergent; LCD-H is comprised of a sodium silicate solution. LCD-H is best used for surgical instruments, metals and soils that require a low pH detergent. LCD-H is recommended for use in all glassware washers.



## LANCER LCA NEUTRALISANT

LANCERACID Rinses are available in three solutions:

**LCA-A:**

Our most commonly used rinsing agent; LCA-A is used in the rinse cycle subsequent to our LANCERCLEAN Detergents. This acetic acid based neutralizer provides an excellent rinse on all standard laboratory soils and contaminants. LCA-A is recommended for use in all glassware washers.

**LCA-C:**

An excellent rinsing agent; LCA-C is used in the rinse cycle subsequently to our LANCERCLEAN Detergents. This citric acid based neutralizer provides an excellent rinse for organics and pharmaceutical based contaminants. LCA-C is recommended for use in all glassware washers.

**LCA-P:**

An exceptional rinsing agent; LCA-P is used in the rinse cycle subsequently to our LANCERCLEAN Detergents. This phosphoric acid based solution works excellently for dealing with petroleum and other difficult soils. LCA-P is recommended for use in all glassware washers.



**Please do not hesitate to consult GETINGE LANCER for application specific solutions.**

## INSTALLATION OF THE WASHING PRODUCTS

The chemical suction diptubes are identified by the following labels :

### NON-FOAMING DETERGENT

Place a container of NON-FOAMING LIQUID DETERGENT inside the drawer. Remove the cap from the detergent container and insert the detergent suction tube into the detergent container. Tighten the cap.

IT IS STRICTLY PROHIBITED TO USE SOLVENTS AS DETERGENT.

PLEASE REFER TO SUPPLIERS MATERIAL SAFETY DATA SHEET FOR SPECIFIC INFORMATION REGARDING THE DETERGENT TO BE USED IN THIS MACHINE.

### NEUTRALIZING ACID

Place a container of NEUTRALIZING ACID inside the drawer. Remove the cap from the acid container and insert the acid suction tube into the acid container. Tighten the cap.

THE USE OF NITRIC AND CHLORHYDRIC ACID IS PROHIBITED. ONLY DILUTE PHOSPHORIC, ACETIC AND CITRIC ACIDS CAN BE USED.

PLEASE REFER TO SUPPLIERS MATERIAL SAFETY DATA SHEET FOR SPECIFIC INFORMATION REGARDING THE ACID TO BE USED IN THIS MACHINE.

### ADDITIONAL PRODUCTS

Place a container of the additional product next to the washer at a maximum height of 150 mm (6") above floor level. Remove the cap from the container and insert the suction tube into the container. Tighten the cap.

Dimensions of 2.5 gal. containers : 14.5 x 6.5 x 9 in.



**BEFORE CARRYING OUT ANY WORK ON THE WASHER,  
MAKE SURE IT IS SWITCHED OFF AT THE DISCONNECTING  
SWITCH.**

## PRECAUTIONS BEFORE USING YOUR WASHER



NEVER USE YOU WASHER WITHOUT PRIOR TRAINING.

Your washer is now properly positioned and installed.

You must read user manual in order to learn how the washer operates.

All personnel using the washer (users and technicians) must have received complete training on use and maintenance.

This training must be carried out on a regular basis and always before the washer is used for the first time.

A record of this training must be stored as evidence that the users attended and understood the contents of the course.

Training should include:

- How the washer functions
- How to load items on the baskets
- The use of the different processing programs
- Review of alarms and the procedure to follow in case of alarm
- Everyday maintenance of the washer (cleaning of external parts, filters...)
- Knowledge of the chemical products utilized
- Management of consumables (change of paper, product containers...)
- The different levels of traceability (if applicable)

---

**LANCER**  
GETINGE GROUP

**Getinge Infection Control AB**  
P O Box 69, SE-305 05 Getinge, Sweden  
Phone: +46 10 335 00 00  
info@getinge.com  
  
www.getinge.com

Legal Manufacturer:  
**Getinge Lancer**  
30 boulevard de l'Industrie  
31170 Tournefeuille, France  
Phone: +33 5 61 15 11 11  
Fax: +33 5 61 15 16 16

---

**GETINGE GROUP**

Getinge Group is a leading global provider of products and systems that contribute to quality enhancement and cost efficiency within healthcare and life sciences. We operate under the three brands of ArjoHuntleigh, Getinge and Maquet. ArjoHuntleigh focuses on patient mobility and wound management solutions. Getinge provides solutions for infection control within healthcare and contamination prevention within life sciences. Maquet specializes in solutions, therapies and products for surgical interventions, interventional cardiology and intensive care.

---