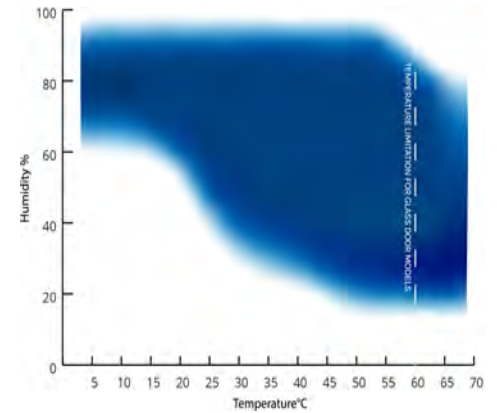

NSRI492WSW/0H
Product Description

Ensure the quality and durability of your products with Corepoint® Scientific Humidity Stability Chambers. These chambers provide a controlled temperature environment to deliver superior product testing that meets ICH Q1A standards. Improve product quality, test packaging, increase shelf life, and enhance safety with these chambers. With natural refrigerants and ultrasonic humidification, these units feature some of the most advanced technology in the industry.

Images

Temperature Chart*

Certifications

General Description and Application

Storage capacity (cu. ft):	49 cu. ft.
Door:	Two solid right and left hinged, self closing, magnetic door gasket for positive seal
Shelves:	Six stainless steel, sliding tray shelves
Drawers:	Not-applicable
Mounting and Installation:	Four swivel casters (3 1/2"), front casters locking
Interior Lighting:	Shielded, switched interior LED lighting
Airflow Management:	Plenum air distribution
External Probe Access:	Probe access port (3/4")
Insulation:	High density urethane foam cabinet and door insulation
Exterior Materials:	Powder coat steel
Access Control:	Keyed door lock
General Warranty:	Eighteen (18) months parts and labor warranty
Compressor Warranty:	Five (5) year compressor parts warranty
Product Weight (lbs):	480 lbs.
Shipping Weight (lbs):	560 lbs.
Rated Amperage:	12 Amps
Power Plug/Power Cord:	NEMA 5-15P conforms to UL471 requirements
Facility Electrical Requirement:	115VAC/60Hz
Agency Listing and Certification:	ETL Listed

Performance

Uniformity (Cabinet Air):	+/- 1°C from 4°C to 70°C
Stability (Cabinet Air):	+/- 0.5°C maximum from 4°C to 70°C
Temperature Control:	+/- 0.1%RH
Humidity Stability:	+/- 3% RH
Temperature Setpoint Range:	4°C to 70°C
Humidity Setpoint Range:	10% to 95% RH
Humidity control:	+/-0.1% RH

Disclaimers:

10-60 PSI demineralized water supply required and floor drain access.
 Specifications are subject to change

Humidity Variation

+/-3% @ +4°C to +70°C* and RH within performance graph. Humidity variation is derived from the maximum deviation of the humidity sensor during the test period.*

Temperature Uniformity

+/-1°C @ +4°C to +70°C. Uniformity is determined by measuring the maximum deviation across 9 thermocouples placed on 3 horizontal planes. Each plane contains thermocouples evenly spaced diagonally from the left and right inner walls, with the central sensor positioned at the approximate geometric center of the shelf.*

*For optimal uniformity at set points above 50°C, settings adjustments may be required based on load conditions and chamber configuration.

Refrigeration System	
Compressor:	Top mounted, variable speed compressor
Refrigerant:	HFC-free refrigerant (R600a)
RH sensor Type:	Capacitive
Temp sensor Type:	NTC
Other:	Multi-element, independent proportional electric heating , ultrasonic humidification, condensate evaporation.

Controller, Configuration, Alarms and Monitoring	
Controller Technology:	Proportional Integral Derivative (PID) microprocessor with LCD display, °C/°F switchable
Battery Backup:	Controller
Display Technology:	LCD display
Digital Communication:	RS-485 (MODBUS)
Data Transfer:	USB port for data transfer and software updates
Chart Recorder:	Not-applicable
Adjustable Temperature Range:	4°C to 70°C
External alarm connection:	State switching remote alarm contacts
Alarms:	Visual alarm indicator, audible alarm indicator, process phase specific temp alarm, process phase specific humidity alarm, power failure alarm, sensor failure alarm
Controller Information:	Programmable ramp and soak Process phase graphic animations USB data port Real time clock Event logs: 100 Process phase specific temp alarm Process phase specific humidity alarm

Dimensions					
	Width (in.)	Depth (in.)	Height (in.)	Door Swing (in.)	Total open Depth (in.)
Exterior	54"	36.375"	81.5"	23"	59.375"
Interior	49.125"	25.5"	52.75"		

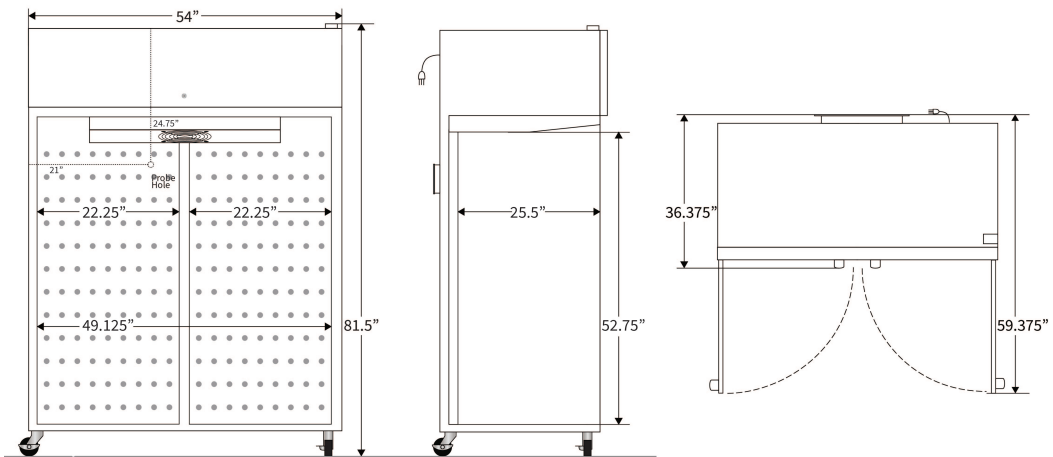

Contact		
Customer Service	800-648-4041 Option 3	customerservice@horizonscientific.com
Technical Service	800-648-4041 Option 5, Parts Option 4	technicalservice@horizonscientific.com