

LABGUARD^{ES}

NU-540 CLASS II TYPE A2 BIOLOGICAL SAFETY CABINET

DESIGNED BY YOU. DESIGNED FOR YOUR APPLICATION.



NuAire, Inc. | 2100 Fernbrook Lane | Plymouth, MN 55447 | U.S.A. | nuaire.com

Sustainability

At NuAire we continually strive to improve our responsibilities to the economy, environment, social communications, and our customer satisfaction. Our commitment extends to purchasing or using products that reduce energy consumption, reduce environmental impact, minimize pollution and make use of recycled content that will not deplete natural resources. We continually use more recycled materials in our cabinets through both design and supplier parts and process improvements. The following chart represents our current level of sustainability for Biological Safety Cabinets.

General Cabinet Component Description	% Content by Weight	% of Recycled Material used in Manufacturing	% Recyclable
Stainless Steel	75%	80%	100%
Mild Steel	10%	10%	100%
Copper	2%	0%	100%
Aluminum	2%	50%	100%
Glass	3%	0%	100%
Electronics	1%	0%	25%
Filter Media	1%	0%	0%
Misc. Plastic Parts	1%	0%	0%
Packing Materials	5%	60%	95%
	100% BSC	65%	97%

Designed By You. Designed for your Application.

The LabGard ES (Energy Saver) model NU-540 is a Class II, Type A2 Biological Safety Cabinet offering Personnel, Product, and Environmental Protection through the use of quality design, an ultra high efficiency motor, and longer lasting filters all at an affordable price.

Join the NuAire family of over 100,000 Biological Safety Cabinets in use throughout the world and learn why NuAire offers the longest lasting, lower cost, and safest Biological Safety Cabinet in the world.



environmental,
product & personnel
protection



Ergonomic Design

NuAire designs equipment that accommodates advancement for: improved safety conditions; improved productivity; improved quality and reliability; and reduction of arm, shoulder, and neck strain contributing to common work place injuries.

- ADA Compliant
- More usable work area
- Shorter reach into work zone
- Recessed air foil
- Recessed work zone
- More knee room
- Ability to sit or stand at a range of heights
- 21" (533 mm) frame-less edge window sash improves vision/sight lines into work zone
- Staggered service valves
- Accessories (elbow rests, armrest foam pads, ergo chair, adjustable base stand, sst turntable)

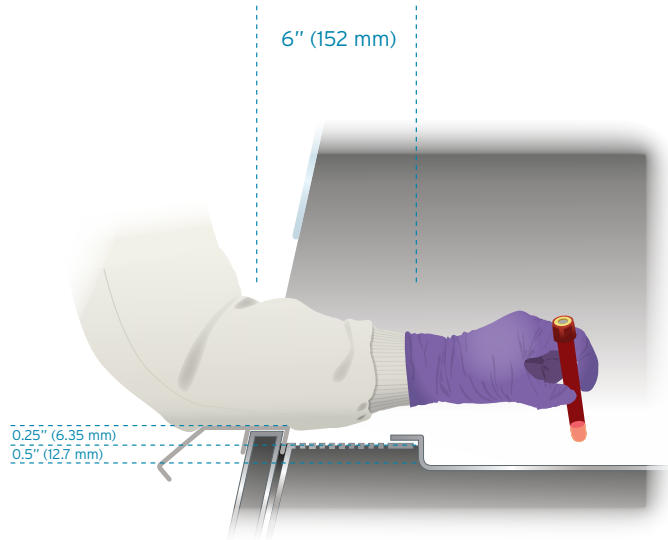



[Larger Work Area]

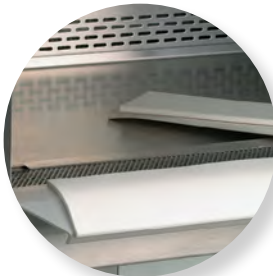

[Disposable Arm Rest Pads]



[Recessed airfoil grill and elbow rest accessory]



[Expanded Vision Zone]

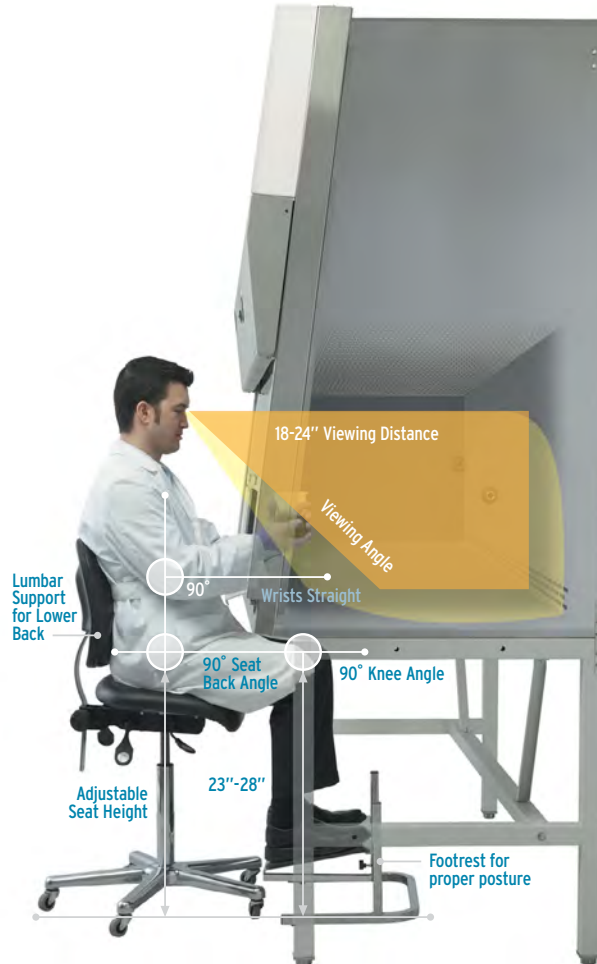

NuAir Quality - Nothing is Built like a NuAir

Monolithic Design. At core of any biosafety cabinet is its basic structure. NuAir has over 100,000 biological safety cabinets in the field; some of which have been running strong since the 1970's.

The NuAir design is a single piece of type 304 stainless steel. A stainless steel wrap [A] makes up the walls of the cabinet. Stainless steel sheets [B] are welded in place to make up the top and bottom of the cabinet. A smaller wrap [C] featuring coved interior corners is welded in place to make up the back wall of the cabinet. This improves the cabinet integrity by creating a double sidewall. New work tray supports [D] help minimize the vibration transfer from the shell of the cabinet to the work zone.

The end result is a monolithic shell of 100% stainless steel [E] without the use of silicone like many multi-piece cabinets. This provides you with a solid foundation for longer product life eliminating potential leaks.

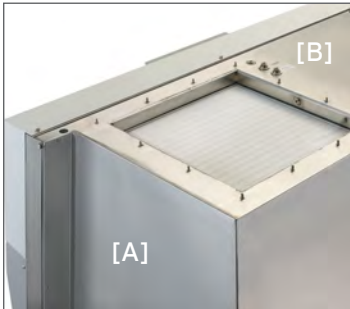

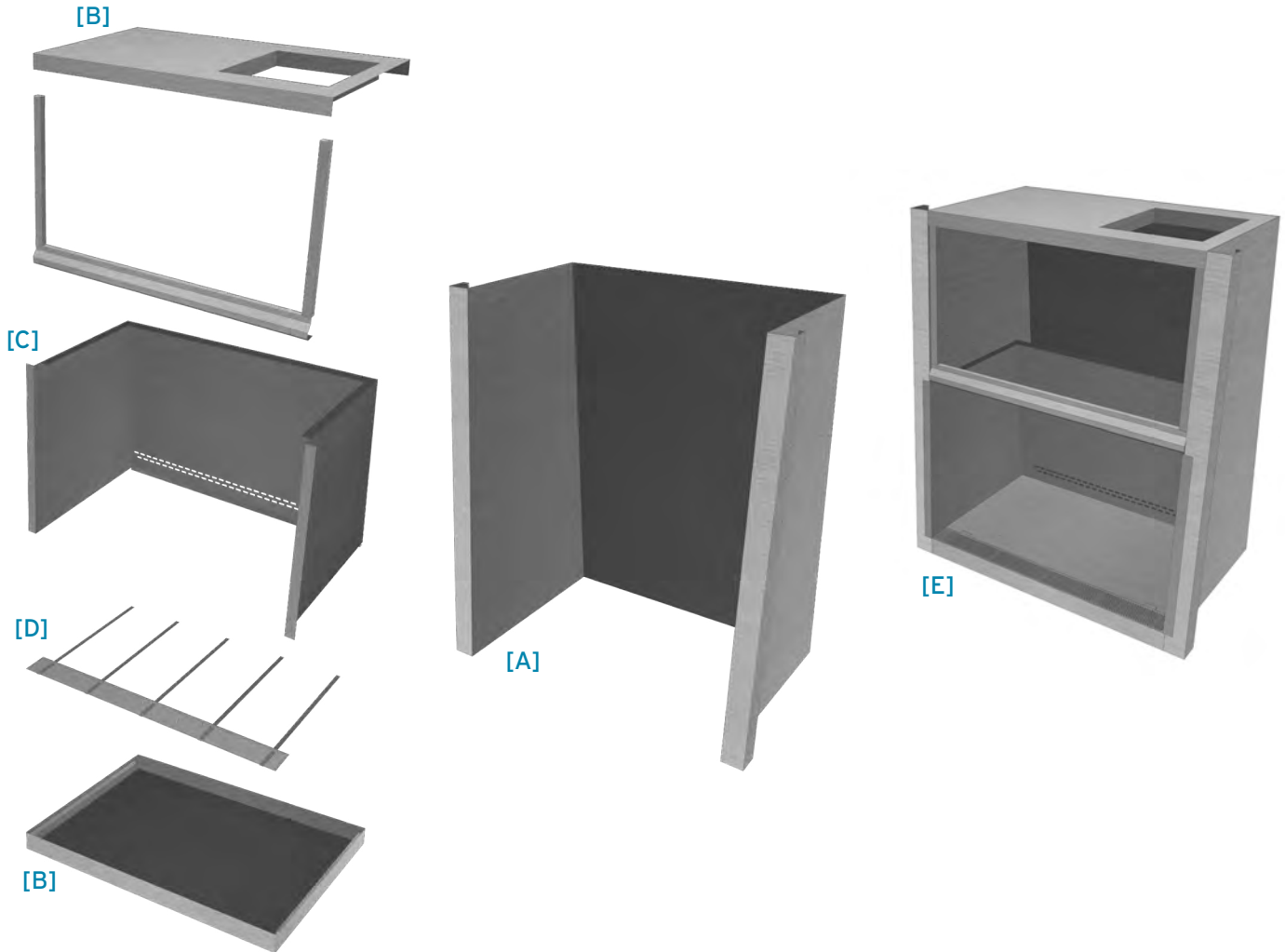

Save More Money Over a Longer Period of Time

Ultra High Efficiency Motor. An ultra-high efficiency ECM motor combined with the properly sized fan blade lowers energy usage while extending the life of filters. LabGard® offers the lowest total cost of ownership compared to other models.

Total cost of ownership breakdown.

Motor Comparison	NuAire DC ECM	NuAire AC PSC	BSC with AC 3-Phase	BSC with DC
8 hrs per day / 5 days per week = 2,000 hrs per year				
KWH per year	598	1128	828	326
\$0.09/kwh	\$54	\$102	\$75	\$29
24 hrs per day / 7 days per week = 8,736 hrs per year				
KWH per year	2612	4927	3617	1424
\$0.09/kwh	\$235	\$443	\$326	\$128
15 Year Life Cycle Costs				
Avg. Filter Changes*	1 Set	2 Sets	1 Set	3 Sets
Estimated Cost of HEPA Filters	\$715	\$1,430	\$715	\$2,145
Total Cost of Decon/Certification	\$450	\$900	\$450	\$1,350
Motors to Replace**	1 Motor	1 Motor	1 Motor	2 Motors
Cost of Motors/ Power Supplies/ Fan Control	\$650	\$420	\$725	\$2,544
Utility Costs (2,000 hrs/yr over 15 years)	\$810	\$1,530	\$1,125	\$435
Total Cost of Ownership	\$2,625	\$4,280	\$3,015	\$6,474

* estimate based on Filter Load capacity

** estimate based on historical information.

Disclaimer: This example is for illustrative purposes only and should not be deemed a representation of future performance or a guarantee of any kind. Information is based on internal performance data obtained through NuAire® testing and information provided by motor, blower, HEPA filter manufacturers, and independent service technicians.

AeroMax Electronic Control System

AeroMax Electronic Control System (ECS) monitors and displays airflow system performance via PresurFlow™ - A specialized digital pressure transducer.

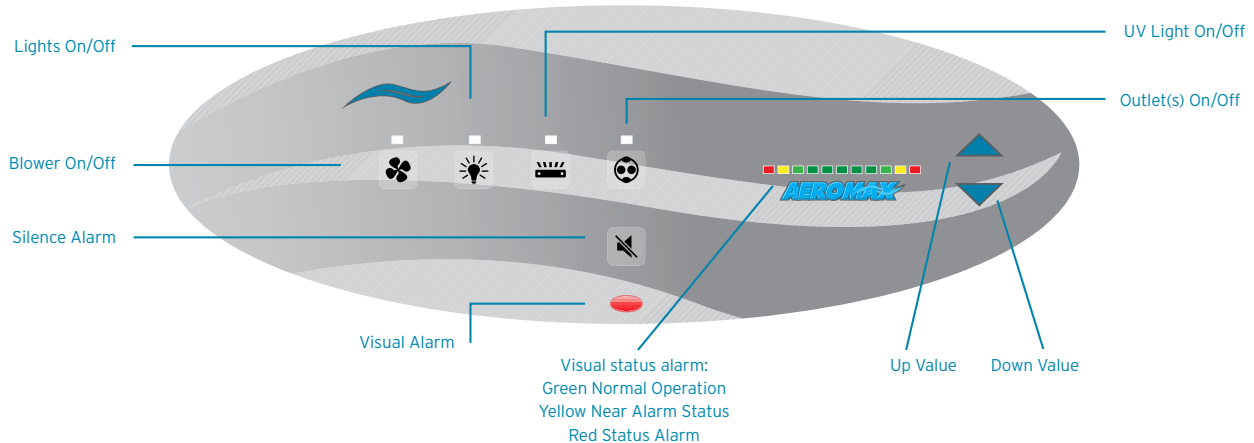

Automatic Filter Load Compensation
Warm up mode
Password Protection

Alarm Ring Back Function
Temperature Sensor compensates pressure sensor inaccuracies caused by operating environment

Software/Hardware Watchdog - automatically reset upon failure to last known status or to blower "ON" to assure containment.
Software updates via USB

Alarms. An audible alarm will sound for 30 continuous seconds then ring back for one second every five seconds until silenced or the alarm condition is cleared. If Silence is pressed, the Silenced alarm condition will be blocked from repeating for a period of 15 minutes.

Window Position

Closed Window
High Window

Airflow Limits

Low Airflow
High Airflow

nitecare™ initiated by the window closure, will reduce motor / blower operational airflow to conserve energy while maintaining work zone sterility.

Your Safety is Our Number 1 Priority

NuAire's commitment to safety doesn't stop at meeting industry standards. NuAire continually performs dynamic tests to push the limits of our product's performance to ensure you and your laboratory personnel will remain safe.

Automatic Airflow Compensation - the Ultra High Efficiency motor will automatically increase or decrease speed to maintain proper airflow settings based on readings from AeroMax ECS.



True laminar (unidirectional) downward moving air flushes the work surface at 60 fpm (0.30 m/s) minimizing cross contamination.

true laminar



A dynamic air barrier at the front of the cabinet separates the laboratory from the work zone environment at an air speed of 105 fpm (0.53 m/s).

dynamic air barrier



The HEPEX Zero Leak Airflow system evenly disperses air over the supply and exhaust HEPA filters, minimizes vibration transfer, and eliminates potential leaks by surrounding positive pressure chambers with negative pressure.

HEPEX zero-leak airflow

Make it Easier on your Service Personnel

We at NuAire® have designed each LabGard® Biosafety Cabinet to be service friendly. **100%** of service functions can be performed at the front or top of the cabinet.

Drop Down Control Panel

A flip down control panel creates a workable tray for service technicians.



Exhaust Choke

Easy Access to exhaust choke to certify airflows.



Front Filter Access

Access filters and the motor blower from the front of the cabinet with the removal of a safety panel.



Decon101 System

Easily connect to a variety of decontamination systems that use Formaldehyde, Chlorine Dioxide or Vapor Phase Hydrogen Peroxide

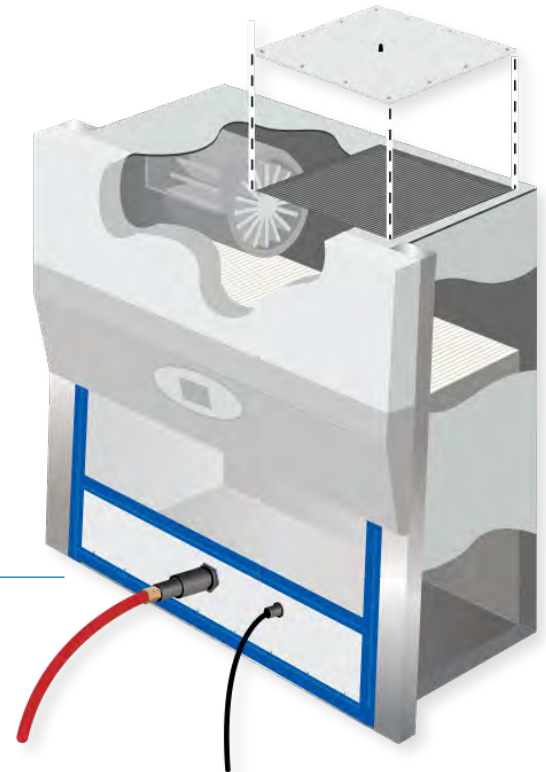

The LabGuard ES is a Class II Type A2 Biological Safety Cabinet that can be either exhausted back into the room or connected to a facility HVAC system. The cabinet's airflow is 30% exhausted / 70% recirculated to minimize cross-contamination of low to moderate risk biologicals in the absence of volatile toxic chemicals.

Specifications

Model	Width Size (nominal)	Electrical (all sizes)	Interior Dimensions (W x D x H) [mm]	Exterior Dimensions (W x D x H) [mm]	Net Weight
NU-540-300	3 ft [0.9 m]	115 VAC / 60 Hz E: 230 VAC / 50 Hz-60 Hz	34 3/8 x 25 3/4 x 28 1/2 [873 x 654 x 724]	41 5/8 x 31 7/16 x 61 7/8 [1057 x 799 x 1572]	400 lbs [181 kg]
NU-540-400	4 ft [1.2 m]		46 3/8 x 25 3/4 x 28 1/2 [1178 x 654 x 724]	53 5/8 x 31 7/16 x 61 7/8 [1362 x 799 x 1572]	465 lbs [211 kg]
NU-540-500	5 ft [1.5 m]		58 3/8 x 25 3/4 x 28 1/2 [1483 x 654 x 724]	65 5/8 x 31 7/16 x 61 7/8 [1669 x 799 x 1572]	550 lbs [249 kg]
NU-540-600	6 ft [1.8 m]		70 3/8 x 25 3/4 x 28 1/2 [1788 x 654 x 724]	77 5/8 x 31 7/16 x 61 7/8 [1972 x 799 x 1572]	620 lbs [281 kg]

WARRANTY - Best products backed by the best warranty.

5 Parts (Filters Included) & Labor (US & CA)

6 Years Parts (Filters Included) (Intl)

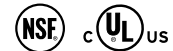
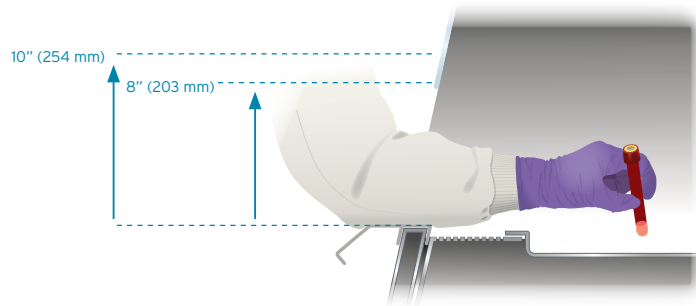
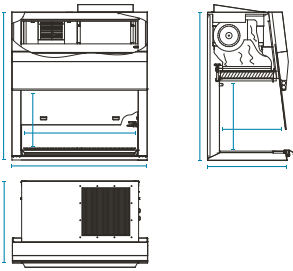

Performance Specifications:

Airflow 30% exhausted / 70% recirculated
 105 fpm (0.53 m/s) Inflow
 60 fpm (0.30 m/s) Down Flow
 Filter Load Capacity 250% plus
 Filter Life +/- 10 Years

Standard Features:

AeroMax Electronic Control System
 Ultra High Efficiency DC/ECM Motor
 Attenumont Vibration Control System
 Motor Speed Controller
 Internal Exhaust Damper
 Monolithic Pressure Tight Design (Silicone Free)
 Permanent Plenum with Quick Release Supply Filter
 3" (76 mm) Metal Frame Supply HEPA Filter 99.99% @ 0.3 microns
 6" (152 mm) Metal Frame Exhaust HEPA Filter 99.99% @ 0.3 microns
 Metal Diffuser Over Supply Filter
 10" (254 mm) Window Sash Access Opening
 Frame-less Sliding Tempered Glass View Window
 External Fluorescent Lighting
 Front Filter Removal
 PVC Plastic Armrest
 Removable Work Tray Support System
 Removable Work Tray
 Removable Airflow Grill
 Spill Trough with Drain Valve
 Two (2) Duplex Outlets Back Wall
 One (1) Service Valve Right Side Wall
 One (1) Service Coupling Right Side Wall
 Two (2) Service Couplings Left Side Wall
 12 ft. (2.5m) Power Cord

Optional Features and Accessories*:

8" (204 mm) Window Sash Access Opening
 Metal Frame Supply ULPA Filter 99.999% @ 0.12 microns
 Metal Frame Exhaust ULPA Filter 99.999% @ 0.12 microns
 Canopy Exhaust Transitions
 Microscope Window
 CuVerro Copper Worksurface
 Ergo-tron Arm for Computer
 Stainless Steel Armrest
 Germicidal Ultraviolet (UV) Light
 LED Lighting (Replaces Fluorescent Lighting)
 IV Bar with Six (6) Hooks
 Duplex Outlets
 GFI Duplex Outlets
 Additional Service Valves/Couplings Up to Three (3) Each Side Wall
 Prop Up Work Tray
 Heated Work Surface
 Storage Pull Out Trays
 Pre-piped Plumbing
 Decorative Side Panels
 Sinks with Hot/Cold or DI Water Faucets
 Telescoping Base Support Stand
 Motorized Base Support Stand
 Base Support Stand Shelf
 Adjustable Footrest
 Elbow Rests
 Armrest Pads
 Custom Solutions

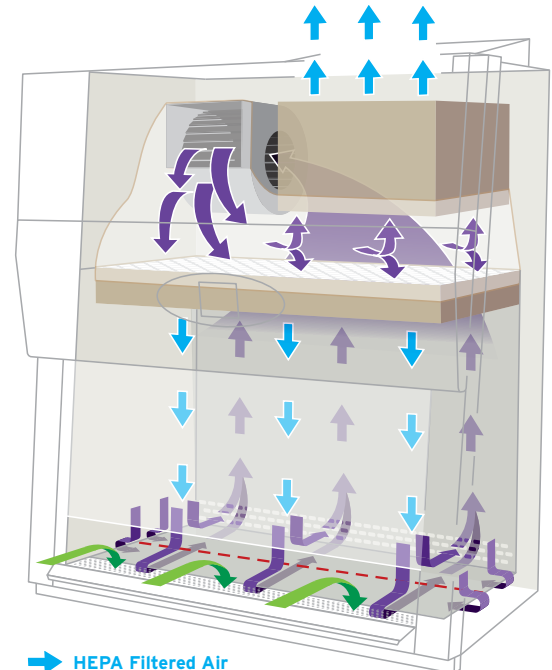

- ➔ HEPA Filtered Air
- ➔ Contaminated Worksurface Air
- ➔ Contaminated Room Air
- - Air Split

*Note: some optional features are not approved by 3rd party listings. Please contact NuAire information.

Design Your Very Own

Each laboratory is unique and every protocol can differ. Set your laboratory up for success by designing your own NuAire Biological Safety Cabinet. It can be as simple as adding a service valve or as involved as customizing the height of the work zone. NuAire can do it all. Invest in a product that lasts and is designed for your needs.

Popular Built-in Options & Accessories



Prop Up Work Surface



Ultraviolet (UV) Light

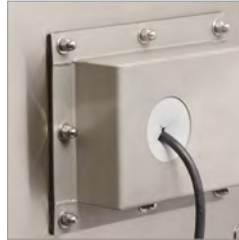

Cord Pass-thru (NSF)

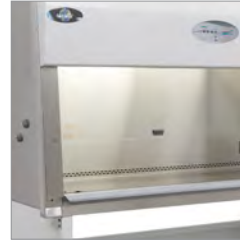

LED Lighting (Replaces
Flourescent Lighting)



Duplex and/or GFI Outlets



IV Bar and SST Hooks

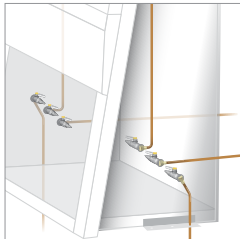

Pre-Piped Plumbing



Service Valves/Couplings
[Gas, Air, Vac]



Microscope Window

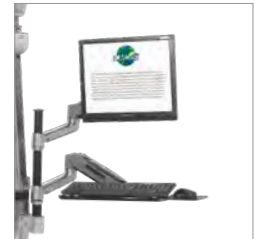

Ergotron[®] arm for monitor and
keyboard/mouse



Arm Rest Pads



Elbow Rest



Motorized Base Stand



Telescoping Leg Leveler
or Castor Base Stand



Base Stand Shelf

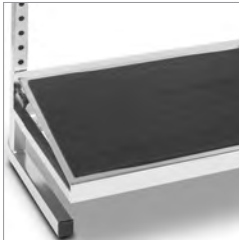

Adjustable Foot Rest



Stainless Steel Turntable



Fixed Exhaust Canopy
Transition w/ Alarm



Flex Duct



Manual and Automatic
Butterfly Valves



8" (204 mm) to 10" (254 mm)
Round Transition



Variable Flow Control (VFC)
Exhaust Transition w/ Alarm



Airflow Alarms



Laboratory Cart



Silicone Connection Kit

Complete your Laboratory

NuAire offers a variety of Laboratory Equipment to meet the needs of the research, vivarium, pharmacy, environmental laboratory and more. Join the NuAire family and complete your laboratory with complementary NuAire Quality products.



LABGUARD
Biological Safety Cabinets



IN-VITROCELL^{ES}
CO₂ Incubators



NUWIND
Centrifuges



Hitachi Koki
HITACHI



BREEZE
Microcentrifuges



Mini-Centrifuges



GLACIER^{ES}
Ultralow Freezers



AIREGUARD^{ES}
Laminar Airflow Workstations



PHARMAGUARD^{ES}
Compounding Isolators



ALLERGUARD^{ES}
Animal Laboratory Products



**Polypropylene Fume Hoods
and Casework**



**Custom Solutions
and Casework**

Delivering product to the customer that is cost effective, exceeds their requirements, delivers product on-time, and increases productivity and profitability.

In every NuAire product you'll find brilliant but practical design, keen attention to detail in every phase of the fabrication and assembly process, thoroughly tested, outstanding value, and dependable service. These are the foundation for NuAire's international reputation, and practical reasons why NuAire is universally recognized as the finest. NuAire's Quality Policy to Satisfy Customers, Comply with Quality System Requirements and Continually Improve.

Sales and Service Like No Other NuAire employs a network of knowledgeable sales and service individuals some of which have been selling and servicing NuAire Laboratory Products since our inception in 1971.

Working safely video series. Learn how to work safely in your NuAire Biological Safety Cabinet with this 7 Chapter online video series.

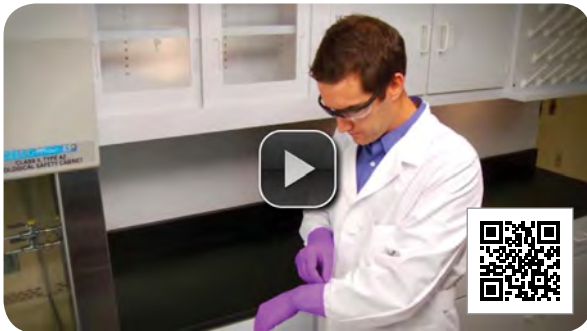

Our Sales Representatives are located throughout the globe providing you with a local individual who can assist product selection, pricing, installation, training, and service throughout the life of your product. Once you buy a NuAire you're a part of our family and we'll work hard to satisfy your needs.

NuAire offers service-training classes and individualize assistance to service professionals in the laboratory community. These NuAire certified companies are located throughout the world allowing NuAire to provide service and assistance to the farthest corners of the earth. Have the option to select from multiple service vendors in your area to find a company that fits your needs.

Contracts, GPO's and many more! NuAire has a variety of Contracts set up through Group Purchasing Organizations, Government Associations, Health Systems, Universities and many more.

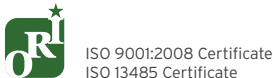

Your Local NuAire Partner

LABRepCo

One Company • Many Solutions

101 Witmer Road, Suite 700
Horsham, PA 19044
p: 1.800.521.0754 | f: 215.442.9200
www.labrepco.com | info@labrepco.com

NuAire, Inc. | 2100 Fernbrook Lane | Plymouth, MN 55447 | U.S.A.

For more information please visit
www.nuaire.com or call 1.800.328.3352

