

REV	CO	DESCRIPTION	DATE	DFTM	CHKD
E	000098	ADDED CORD PASS-THRU	9/5/2019	TH	DSH

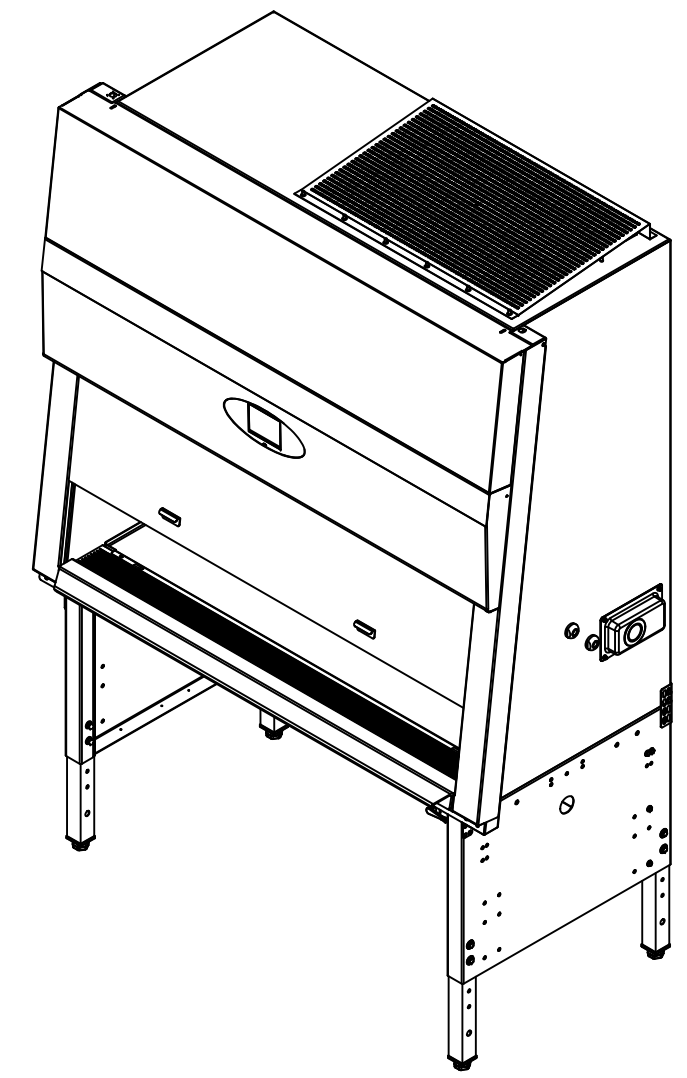
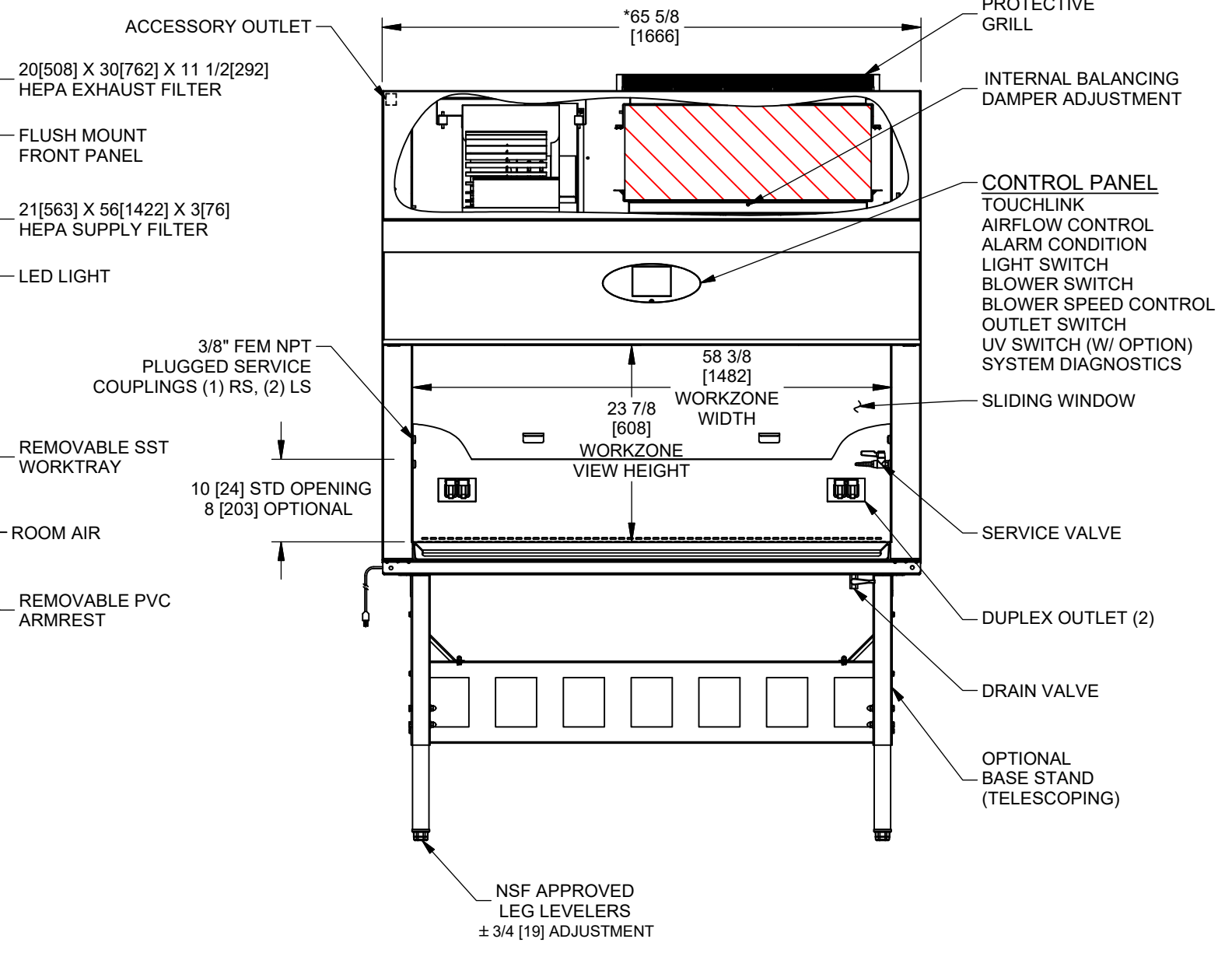
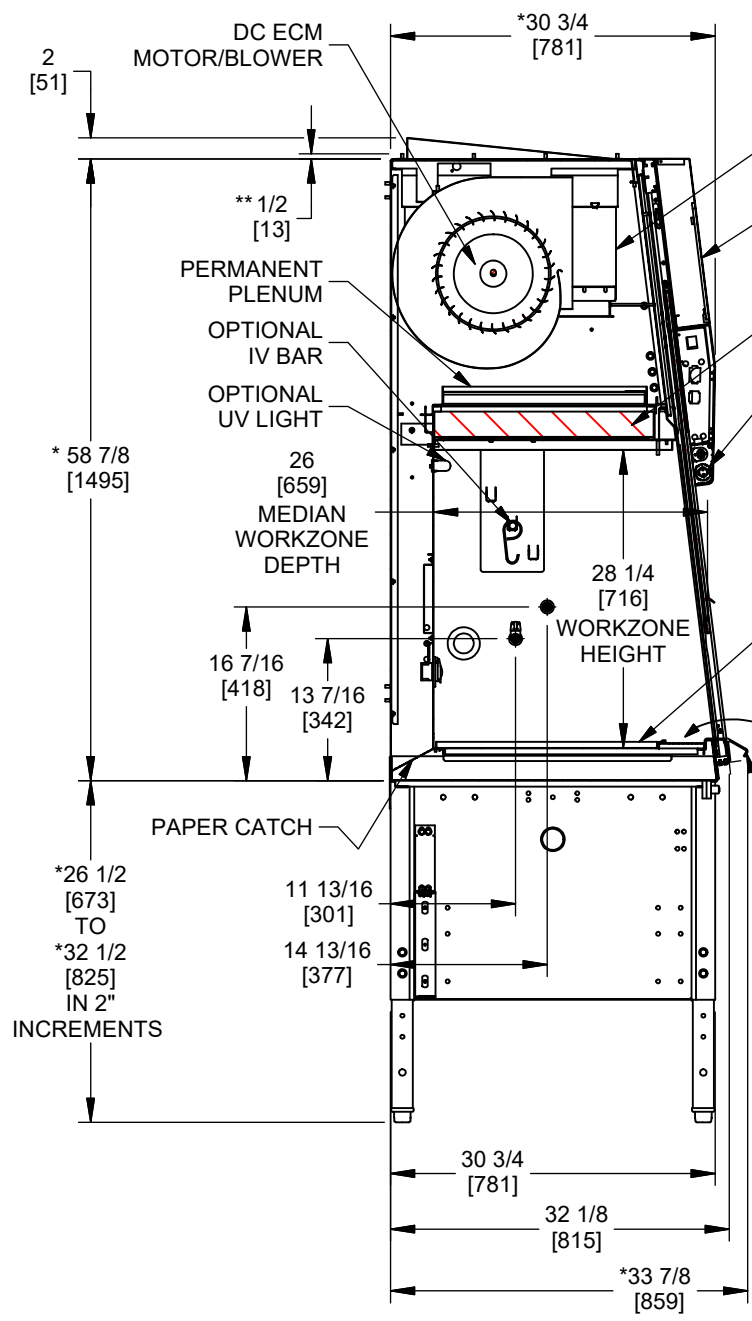
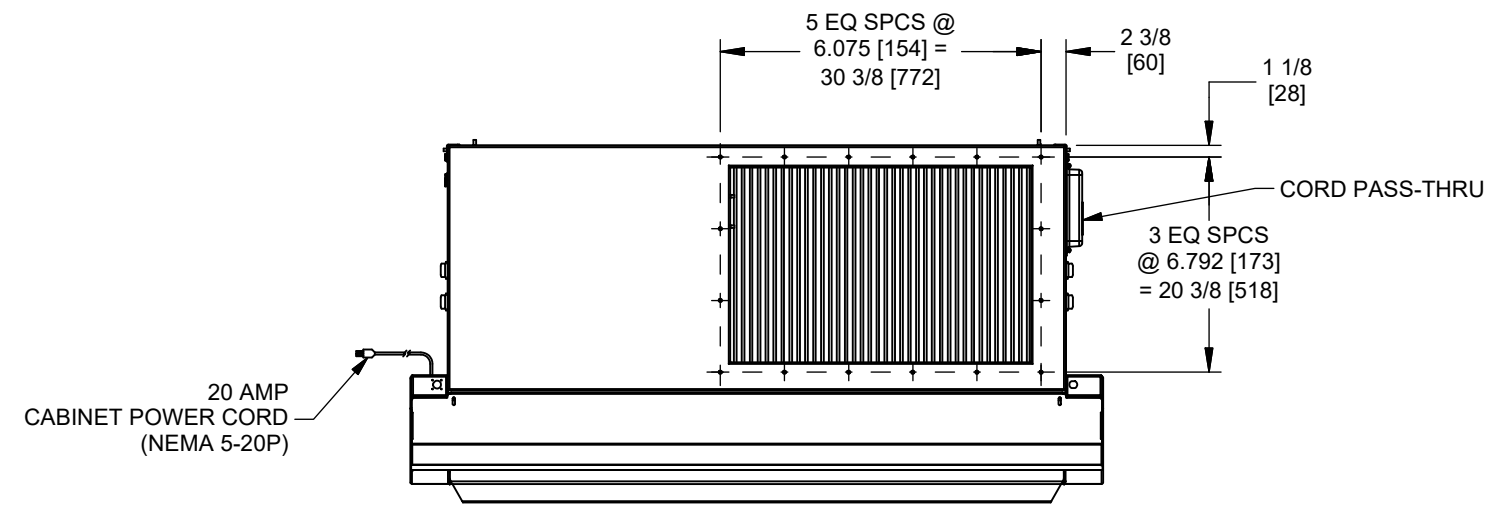

* OVERALL DIMENSIONAL TOLERANCE ±1/4 [6.35]
ALL OTHER DIMENSIONS ±1/8 [3.17]

TITLE NU-545-500 Class II Type A2 Biosafety Cabinet					
DFTM LS	DATE 9/12/2013	CHKD DSH	SHEET 1	OF 1	
DRAWING NUMBER		BCD-16206			E

** ADD 1/2" [13] TO OVERALL HEIGHT WITH PROTECTIVE GRILL REMOVED
INCH MILLIMETER