



MCO-50AICL-PA

cellIQ™

CO<sub>2</sub> Incubator



The Cell-IQ MCO-50AICL-PA incubator is engineered to precisely and accurately control CO<sub>2</sub> and temperature for optimal culturing conditions. This incubator features standard and optional passive and active contamination mitigation systems with a three-hour H<sub>2</sub>O<sub>2</sub> vapor option for thorough and complete resolution of bacteria and viruses in a compact design that can be double or triple stacked.

### Responsive Performance

A stable and uniform temperature is maintained by the Direct Heat and Air Jacket system. CO<sub>2</sub> is quickly restored to setpoints after door openings, while relative humidity returns to an elevated state to prevent media desiccation. A streamlined interior maximizes space and reduces contamination risk while improving ease of maintenance. A Peltier dew stick provides optimal humidity control by removing condensation from the interior chamber.

### Contamination Control

Exclusive inCu-saFe® alloy interior provides the germicidal properties of copper with the corrosion resistance of stainless steel. Optional SafeCell™ UV light, safely destroys contaminants at the humidification source from behind a plenum wall. A high-speed H<sub>2</sub>O<sub>2</sub> vapor decontamination option utilizes a combination of vaporized hydrogen peroxide and UV light to permeate and safely clean the chamber in less than 3 hours to achieve a minimal 6 log reduction of major contaminants. H<sub>2</sub>O<sub>2</sub> vapor is reduced to water vapor by the UV light.

### Event Management

The microprocessor controller manages and records incubator functions and user inputs through an arrow prompted touchscreen menu. Events and parameters include temperature, CO<sub>2</sub>, humidity, door open/close status and timing, UV status and parameter deviation alarms. Dual infrared CO<sub>2</sub> sensor maintains setpoint to within 0.15% or better and requires minimal calibration.



### Precision Gas Sensor Dual IR CO<sub>2</sub>

Unaffected by temperature or humidity changes, the dual infrared CO<sub>2</sub> sensor continuously calibrates for control and accuracy. Dual sensors deliver real-time chamber CO<sub>2</sub> density readings for optimal recovery after door openings. A white LED graphic user interface control panel delivers full control over inner chamber environment and alarms.



### Easy to Clean

Integrated inCu-saFe shelf design facilitates a seamless interior chamber that mitigates contamination while remaining easy to clean and remaining corrosion free. Shelf channels are molded into the sidewalls, minimizing moving parts and eliminating the need for brackets and clips.



### Advanced Touchpanel Controller

An intuitive controller provides full control over interior incubator chamber parameters. Temperature, CO<sub>2</sub> and humidity setpoints and alarm deviations are controlled on a white LED graphic user interface control panel for ease of use, even with gloved hands. Standard USB data port permits convenient transfer of logged performance.

### Time-Saving Decontamination

The high-speed decontamination system uses vaporized hydrogen peroxide and UV light. It cleans the chamber of the incubator safely in less than 3 hours, achieving a minimal 6 log reduction of all contaminants.

### Temperature Pull-Down/Pull-Up Characteristics

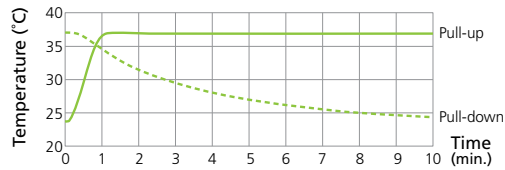

### Temperature Recovery Characteristics

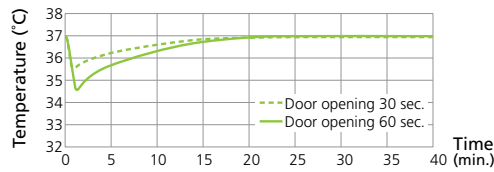

### Humidity Recovery Characteristics

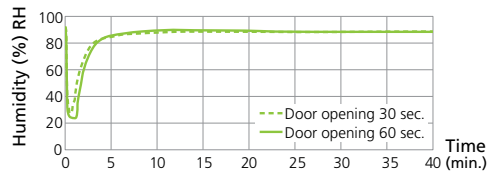

### CO<sub>2</sub> Level Recovery Characteristics

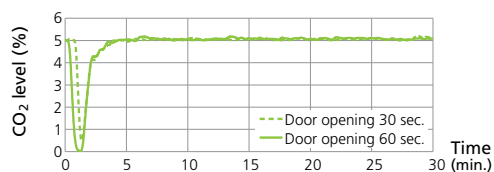

### Dimensions

Unit : inch | mm

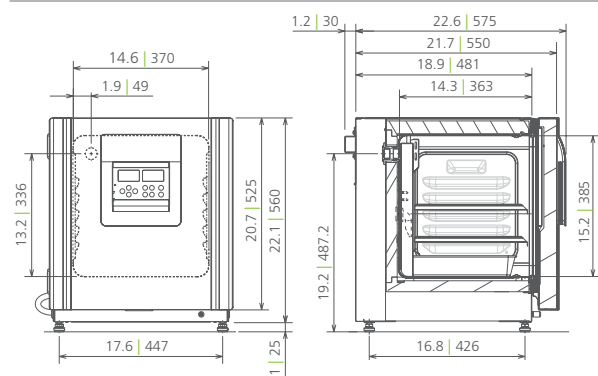

Model Number	MCO-50AICL-PA	With Optional UV Decontamination	With Optional H <sub>2</sub> O <sub>2</sub> Decontamination	
External Dimensions (W x D x H) <sup>1)</sup>	inches   mm	18.9 x 21.7 x 23.0	480 x 550 x 585	
Internal Dimensions (W x D x H)	inches   mm	14.6 x 14.3 x 15.2	370 x 363 x 385	
Volume	cu. ft.   liters	1.8	50	
Net Weight	lbs   kg	99	45	
<b>Performance</b>				
Warranty <sup>2)</sup>		3 years parts and labor		
Temperature Control Range and Fluctuation <sup>3)</sup>	°C	+5 above ambient to +50, ± 0.1		
Temperature Uniformity <sup>3)</sup>	°C	± 0.25		
CO <sub>2</sub> Control Range and Fluctuation <sup>3)</sup>	%	0 to 20, ± 0.15		
Humidity Level & Fluctuation	% RH	95 at 37°C, ± 5 (natural evaporation with humidifying pan)		
<b>Control</b>				
Controller		Microprocessor – digital with soft keys		
Temperature Sensor		Thermistor		
Display	qty	White graphic OLED – (temperature, CO <sub>2</sub> ) readable to 0.1 increments		
Sensor	CO <sub>2</sub>	Dual IR		
<b>Construction</b>				
Exterior Material		Painted steel (rear cover coated steel)		
Interior Material		Stainless steel copper enriched alloy		
Outer Door	qty	1; Field reversible		
Inner Door	qty	1; Sealing tempered glass with positive latch		
Humidity Pan		1; Stainless steel		
Shelves	qty	2; Stainless steel copper enriched alloy		
Shelf Dimension (W x D x H)	inches   mm	13.9 x 12.1 x 0.5   353 x 308 x 12		
Max. Load per Shelf	lbs   kg	15.4   7		
Max. Total Load	lbs   kg	30.9   14		
Max. Shelf Capacity	qty	5		
Access Port / Position	qty	1; On back wall, upper left side		
Access Port Diameter	inches   mm	1.2   30 with silicone (non-VOC) stopper		
Leveling Feet	qty	4		
<b>Decontamination Control</b>				
InCu-safe Chamber, Air Plenum and Shelves	passive	Included (stainless steel copper enriched alloy)		
SafeCell UV Light System	passive/active	Optional	Included	Included
Hydrogen Peroxide (H <sub>2</sub> O <sub>2</sub> ) Vapor	active	Optional	Optional	Included
<b>Alarms</b> (V=Visual Alarm, Buzzer Alarm, R=Remote Alarm)				
Power Failure		R		
Temperature Deviation	high	V-B-R		
Gas Deviation	CO <sub>2</sub>	V-B-R		
Supply Empty	CO <sub>2</sub>	V-B-R		
Door Open		V-B		
<b>Electrical and Noise Level</b>				
Power Supply		115V, 1Ø, 60Hz, NEMA 5-15P requires NEMA 5-15R receptacle		
Noise Level <sup>4)</sup>	dB(A)	29		
<b>Options</b>				
SafeCell UV Light System		MCO-170UVS-PA	Included	Included
Hydrogen Peroxide (H <sub>2</sub> O <sub>2</sub> ) Vapor Board		MCO-50HB-PW <sup>5)</sup>	MCO-50HB-PW <sup>5)</sup>	Included <sup>5)</sup>
Outer Door–Password Access Electronic Lock		MCO-170EL-PW <sup>5)</sup>	MCO-170EL-PW <sup>5)</sup>	Included <sup>5)</sup>
H <sub>2</sub> O <sub>2</sub> Vapor Generator			MCO-50HP-PW <sup>5)</sup>	
H <sub>2</sub> O <sub>2</sub> Reagent	package of 6		MCO-5H2O2-PV	
CO <sub>2</sub>   N <sub>2</sub> Gas Pressure Regulator	psi		0 – 15; MCO-100L	
Automatic CO <sub>2</sub> Cylinder Changeover System			MCO-50GC-PW	
4-20mA Analog Output			MCO-420MA-PW	
inCu-safe Shelf		MCO-50ST-PW (stainless steel copper enriched alloy)		
Double Stacking Bracket <sup>6)</sup>		MCO-170PS-PW (two required for stacking three MCO-50 series incubators)		
Roller Base			MCO-50RB-PW	
Stacking Plate			MCO-50SB-PW	
<b>Optional Communication System</b>				
Wireless, Cloud-Based, Automatic Data Management		LabAlert® Monitoring System		
<b>Quality Management System</b>				
Certification		QPS Listed		

<sup>1)</sup> Exterior dimensions of main cabinet only, excluding handle and other external projections  
<sup>2)</sup> Current warranty offered at time of printing and may be subject to change; US and Canada only  
<sup>3)</sup> Ambient temperature 23°C, setting 37°C, CO<sub>2</sub> 5%, no load, air temperature measured at incubator center  
 • MCO-50AICL-PA is for laboratory use  
 • The optimum performance may not be obtained if the ambient temperature is not above 15°C  
<sup>4)</sup> Nominal value – Background noise 20 dB(A)  
<sup>5)</sup> MCO-50AICL-PA requires MCO-50HB-PW, MCO-170EL-PW, MCO-50HP-PW and MCO-170UVS-PA for H<sub>2</sub>O<sub>2</sub> decontamination  
<sup>6)</sup> If stacking two incubators, make sure the double stacking dedicated secure hardware and spacer are used  
 Note: Additional options available.

Specifications are subject to change without notice.

For latest specification information contact PHC Corporation of North America at info@us.phcd.com. Performance data herein is based on independent testing at time of publication.