

PHCbi

Operating Instructions

Ultra-Low Temperature Freezer

MDF-DU700ZHA

MDF-DU500ZHA



MDF-DU700ZHA

Please read the operating instructions carefully before using this product, and keep the operating instructions for future use.

See page 58 for the model number.

CONTENTS

1. BEFORE USING

INTRODUCTION	4
SAFETY PRECAUTIONS	5
SYMBOLS ON UNIT	9
FOR SAFELY STORING SAMPLES	10
About backup cooling system	10
In the event of emergency	11
INSTALLATION SITE	12
INSTALLATION	13
FREEZER COMPONENTS	14
Main body	14
Accessories	16
Remote alarm terminals	16
Locking/unlocking the outer door	17
Air intake port	17
START-UP PROCEDURE	18
DURING/AFTER POWER FAILURE	19
Operation during power failure	19
Operation after recovery from power failure	19

2. TOUCH PANEL OPERATION

USING THE TOUCH PANEL	20
Basic Operation	20
Entering alphanumeric values and symbols	20
Other operations	21
TOP SCREEN	22
MENU SCREEN	23

3. SETTINGS AND OPERATION

SETTING FOR BASIC OPERATION	24
Setting temperature and high/low alarms	24
Configuring alarm settings	25
About alarm test	26
Setting compressor delay time	27
KEY LOCK	28
Setting key lock	28
Operation when key lock is ON	30
Cancelling key lock setting	30
OTHER SETTINGS	32
Setting date and time	32
Setting brightness and sleep	33
Setting DAQ	34
OPERATION LOG	35
Setting log interval and unique ID	35
OPERATION LOG	36
Displaying operation log chart	36
Exporting the operation log data displayed on the screen	37
Exporting operation log data	39
ALARM LOG	41
Referring to the alarm logs	41
Exporting alarm log data when referring to the data	42
Exporting alarm log data	44

4. MAINTENANCE & TROUBLESHOOTING

ALARMS AND SELF-DIAGNOSIS	46
Warning messages	46
Alarm messages	47
Status messages	47
Alarm and Buzzer button	48
ROUTINE MAINTENANCE	49
Cleaning the exterior, interior, and accessories	49
Cleaning the condenser filter	49
Defrosting the chamber	50
Cleaning the air intake port	50
REPLACEMENT OF CONSUMABLE PARTS	51
Replacing the battery for power failure alarm	51
Replacing the battery for backup cooling system (option)	51
CALIBRATION	51
TROUBLESHOOTING	52
DISPOSAL OF UNIT	52
Recycle of battery	54

5. OPTIONS & SPECIFICATIONS etc.

OPTIONAL COMPONENTS	55
Temperature recorder (MTR-85H, MTR-G85A)	55
Backup cooling kit (MDF-UB7)	55
SETTING OF SHELF STOPPERS WHEN USING INVENTORY RACKS	56
SPECIFICATIONS	57
PERFORMANCE	58
SAFETY ENVIRONMENTAL CONDITIONS	59
SAFETY CHECK SHEET	60

1. BEFORE USING

INTRODUCTION

- Read the operating instructions carefully before using the product and follow the instructions for safe operation.
- PHC Corporation takes no responsibility for safety if the product is not used as intended or is used with any procedures other than those given in the operating instructions.
- Keep the operating instructions in a suitable place so that they can be referred to as necessary.
- The operating instructions are subject to change without notice for improvement of performance or function.
- Contact our sales representative or agent if any page of the operating instructions is lost or the page order is incorrect, or if the instructions are unclear or inaccurate.
- No part of the operating instructions may be reproduced in any form without the express written permission of PHC Corporation.

IMPORTANT NOTICE

PHC Corporation guarantees this product under certain warranty conditions. However, please note that PHC Corporation shall not be responsible for:

- any loss or damage to the contents of the product
- any indirect damage caused by data damage or loss

<Intended Use>

This equipment is designed for low temperature storage of biomedical samples.

SAFETY PRECAUTIONS

Be sure to observe the operating instructions as they contain important safety advice.

For correct and safe use of the product, follow the precautions and procedures in these operating instructions carefully. Failure to do so could result in injury or damage to the product.

Precautions are illustrated in the following way:







WARNING

Warning indicates a potentially hazardous situation which, if not avoided, could result in serious injury or death.

CAUTION

Failure to observe CAUTION signs could result in injury to personnel and damage to the unit and associated property.

The following symbols are used in this document and some of them are attached to the unit.

	<p>Actions are prohibited. The illustration in the circle and the description adjacent to the symbol provide detailed information about the action which is prohibited.</p>
	<p>Actions are mandatory. The illustration in the circle and the description adjacent to the symbol provide detailed information about the action to be taken.</p>
	<p>Caution must be taken. The description adjacent to the symbol provides detailed information about the caution to be taken.</p>
	<p>This symbol indicates the possibility of an electric shock. High-voltage electrical components are placed under the covers. Only a qualified engineer or service personnel should be allowed to open these covers.</p>
	<p>This symbol indicates that there is flammable gas inside the unit. There may be a risk of fire or explosion. Keep away from any ignition sources.</p>
	<p>This symbol indicates low temperature or freezing conditions. Take care to avoid exposure to low temperature or freezing conditions.</p>
	<p>This symbol indicates earth. Connect the earth terminal to the ground to prevent an electric shock.</p>

For the State of California, USA Only:

This product contains a CR Coin Cell Lithium Battery which contains Perchlorate Material – special handling may apply. See www.dtsc.ca.gov/hazardouswaste/perchlorate.

SAFETY PRECAUTIONS

WARNING

Installation



- **Do not use the unit outdoors.**
Exposure to rain may cause an electric leakage and/or an electric shock.
- **Do not install the unit in a location where flammable or volatile substances are present.**
Installing the unit in such a location may cause explosions and/or a fire.
- **Do not install the unit in a location where there are high levels of moisture or where it may be splashed with water.**
This may cause the insulation to deteriorate, leading to an electric leakage and/or an electric shock.
- **Do not install the unit in a location where corrosive gases such as acids are present.**
Deterioration of the insulation due to corrosion of the electric components may cause an electric leakage or an electric shock. Also, corrosion of the refrigerant piping can result in explosions and/or a fire caused by gas leakage.
- **Do not leave the plastic bags used for packing in a place where they can be reached by children.**
This may result in unexpected accidents such as suffocation.



- **Only qualified engineers or service personnel should install the unit.**
Installation by unqualified personnel may cause water leakage, an electric shock, or a fire.
- **Install the unit in a location capable of bearing the total combined weight (product + optional accessories + stored items). After installing the unit, be absolutely sure to take precautions to prevent the unit from falling over.**
If the unit is installed in a location which is not strong enough or if the proper precautions are not taken, the unit may fall over and cause injuries.
- **Use the fixtures on the back panel of the unit, and secure the unit to the wall by passing a strong rope or chain through the fixtures.**
The unit may tilt or fall over, causing injuries.
- **Connect the unit to a dedicated power source as indicated on the rating label attached to the unit.**
Use of any other voltage or frequency other than that on the rating label may cause a fire or an electric shock. Also, a power strip may cause a fire resulting from abnormal heating.
- **When handling harmful samples (for example, those which consist of toxic, pathogenic or radioactive substances), install the unit inside a designated isolation facility.**
If the unit is installed in a location other than an isolation facility, there may be detrimental effects on both people and the natural environment.
- **Install the unit in a well-ventilated (airy) location to prevent the accumulation of flammable refrigerant.**
 - If flammable refrigerant leaks, it may accumulate and cause explosions or a fire.
 - (When optional backup cooling system is installed) As with any equipment that uses CO₂ gas, there is a likelihood of oxygen depletion in the vicinity of the equipment. It is important that you assess the work site to ensure there is suitable and sufficient ventilation. If lack of ventilation is suspected, then other methods of ensuring a safe environment must be considered. These may include atmosphere monitoring systems and warning devices with alarms.
- **Risk of fire or explosion. Flammable refrigerant used.**
The unit contains flammable refrigerant. Consult repair manual/owner's guide before attempting to install or service this product. All safety precautions must be followed.
- **This unit must be plugged into a dedicated circuit protected by branch circuit breaker.**
Otherwise it may cause an electric shock or a fire.



- **Be absolutely sure to earth (ground) the unit to prevent an electric shock.**
Failure to earth the product may cause an electric shock. If necessary, ask a qualified contractor to do this work.
- **Do not connect the earth wire to a gas pipe, water pipe, or lightning rod when earthing the unit.**
Earthing the unit improperly may cause an electric shock.

⚠ WARNING

Power supply plug and cord



- **Never damage the power supply cord or power supply plug (by breaking, adapting, placing near a source of heat, bending with force, twisting, pulling, adding weight, or binding).**

A damaged power supply cord or power supply plug may cause an electric shock, a short circuit, or a fire. Contact our sales representative or agent for repairing the cord and plug.

- **Do not place this unit or other equipment in a position where it is difficult to disconnect the power supply plug.**

Failure to disconnect the power supply plug may cause a fire in the event of a problem or malfunction.

- **Do not pull the power supply cord, the power supply plug, or the product side plug (inlet part) hard.**

If the cord breaks, it may cause electric shock or fire.

- **Do not use power cord for other electrical equipment.**

Such power supply cord may cause fire or electric shock.



- **Do not plug or unplug the power supply plug with wet hands.**

This may cause an electric shock.



- **Remove dust from the power supply plug periodically.**

Dust on the power supply plug may lead to an insulation failure due to moisture and thus cause a fire. Disconnect the power supply plug and wipe it with a dry cloth.

- **Make sure the power supply plug is pushed fully in.**

Faulty insertion of the power supply plug may cause an electric shock or a fire due to a generation of heat. Never use a damaged power supply plug or loose power outlet.

- **Grip the power supply plug when disconnecting the power supply cord from the outlet.**

Pulling the power supply cord may cause an electric shock or a short circuit.

- **Always use the detachable power supply cord that came with the product.**

Other power supply cord may cause electric shock or fire.



- **Disconnect the power supply plug before moving the unit.**

Take care not to damage the power supply cord. A damaged power supply cord may cause an electric shock or a fire.

- **Disconnect the power supply plug when the unit is not in use for long periods.**

Keeping the unit connected may cause an electric shock, an electric leakage, or a fire due to the deterioration of insulation.

- **Before proceeding with maintenance or checking the unit, turn off the power switch (if the switch is provided), and disconnect the power supply plug.**

Performing the work while power is still being supplied to the product or while the power supply plug is still connected may cause an electric shock and/or injuries.

When something is wrong with the unit



- **Never disassemble, repair, or modify the unit yourself.**

A high-voltage area is located inside the unit. Any work carried out by unauthorized personnel may result in an electric shock. Contact our sales representative or agent for maintenance or repair.



- **Turn off the power switch and disconnect the power supply plug if something is wrong with the unit.**

If the unit keeps running under such conditions, there may be a risk of an electric shock or a fire. Contact our sales representative or agent immediately for maintenance or repair.



- **Use designated parts for parts replacement.**

Using an incorrect part may cause a fire.

SAFETY PRECAUTIONS

WARNING

When using the unit



- **Never put containers with liquid on top of the unit.**
This may cause an electric shock or short circuit if the liquid is spilled.
- **Never insert metal objects such as pins and wires into any vent, gap, or outlet on the unit.**
This may cause an electric shock or injury by accidental contact with moving parts.
- **Do not use equipment or other measures for facilitating the defrosting work other than the scraper included with this product.**
It may cause explosions and/or a fire in case of refrigerant leakage.



- **Never splash water directly onto the unit.**
This may cause an electric shock or short circuit.



- **Never store volatile or flammable substances in this unit except in a sealed container.**
Such substances may cause an explosion or a fire if they leak.
- **Ask a qualified contractor to carry out replacement of the battery for the power failure alarm and the battery for backup cooling system.**
Improper handling will result in an electric shock or a fire.



- **Do not give strong shock or vibration when moving or using the unit.**
The piping may be damaged, causing a fire.
- **Never damage the chamber wall when removing frost.**
It may cause explosions and/or a fire in case of refrigerant leakage.



- **Flammable and explosive product.**
The unit contains flammable refrigerant. When repairing or recycling the unit, only trained service personnel should perform the work. Follow the procedure below.
 - Well ventilate the room to prevent refrigerant accumulation.
 - Keep fire away when the refrigerant is contained in the product.
 - Do not damage or break the pipework.It may cause explosions and/or a fire in case of refrigerant leakage.

When storing and disposing the unit



- **If the unit is to be stored unused in an unsupervised area for a long period, ensure that children do not have access to the unit and that doors cannot be closed completely.**
There may be a risk of child entrapment.
- **Ask a qualified contractor to carry out disassembly/disposal of the unit and do not leave the unit in a location that can be accessed by third parties**
This may result in unexpected accidents (e.g. the unit may be used for unintended purposes).
- **The unit contains flammable refrigerant and flammable blowing gas. When the unit is disassembled or disposed of, the work must be performed in a well-ventilated place and avoid the place near fire.**
It may cause explosions and/or a fire in case of refrigerant or gas leakage.

CAUTION



- **Do not touch stored samples in the chamber or inner walls of the chamber with bare hands.**

Frostbite can occur at low temperatures. Wear insulated gloves when reaching into the chamber.



- **Do not climb on top of the unit or put any objects on the unit.**

Falling from the unit may cause injury; falling objects may cause damage to the unit.



- **Turn the leveling feet to raise the casters above the floor and secure the unit.**

If they are left touching the floor, the unit may inadvertently move out of position when its door is opened or closed. It may cause injury.

- **Never store corrosive substances such as acids or alkalis in this unit except in a sealed container.**

These may be harmful to your health and may cause corrosion of internal components or electrical parts.

- **Wear protective gloves when handling frozen items or cleaning the chamber.**

Without gloves, you may get frostbite or get injured by the corners of interior parts.

Also, touching or inhaling chemicals or aerosols from around the unit may be detrimental to health.

- **Never open the inner door by force when the inner door is hard to open due to the difference in pressure inside and outside of the inner door.**

Opening the door by force may damage the inner door latch or cause injuries.



- **When moving the unit, be sure to take precautions to prevent it from falling over.**

Moving the unit with too much force may cause it to fall over, possibly resulting in injury. A qualified individual must be assigned to supervise the safe movement and relocation of the unit.

- **Set up or remove the shelf with both hands.**





If the shelf falls down, it may cause injury.

- **When using the optional inventory racks, be careful not to drop the racks.**

If the rack falls down, it may cause injury or damage to the contents.

SYMBOLS ON UNIT

The following symbols are attached to the unit.

	This symbol indicates possibility of an electric shock. High-voltage electrical components are placed under the covers. Only a qualified engineer or service personnel should be allowed to open these covers.
	This symbol indicates that caution is required. Refer to product documentation for details.
	This symbol indicates incorrect usage could lead to a fire hazard.
	This symbol indicates low temperature or freezing conditions. Take care to avoid exposure to low temperature or freezing conditions.
	This symbol indicates an earth.
	This symbol indicates the "ON" for the power switch.
○	This symbol indicates the "OFF" for the power switch.

FOR SAFELY STORING SAMPLES

Ultra-low temperature freezers control temperature by mechanical systems that run on electricity. If the systems stop due to a power failure or some other reason, the temperature in the freezer rises. The following tips can help protect your valuable samples from unexpected failure of the freezer.

- Store valuable samples separately into multiple ultra-low temperature freezers.
- Install the temperature recorder, backup cooling system, and remote alarm system for protecting samples.
- Use the remote alarm system to ensure that the alarm notifies the administrator of the unusual status of the freezer. Especially, the use of the remote alarm system is recommended if the freezer is placed in an unattended environment.
- Replace the battery for backup cooling system and the battery for power failure alarm every three years. They are consumable parts. If the battery drains, audible alarms do not sound and the backup cooling system does not work. Contact our sales representative or agent for the replacement of the batteries.

Note:

PHC Corporation shall not be responsible for any loss or damage to the samples stored in the freezer.

About backup cooling system

When the unit stops operation in the event of a power failure, the optional backup cooling kit MDF-UB7 and the liquid CO₂ cylinder can prevent the chamber temperature from rising for several hours by injecting liquid CO₂ into the chamber. For details about the backup cooling system, refer to page 55. For purchase of the backup cooling kit, contact our sales representative or agent.

Note:

The cooling function of the backup cooling system can last only several hours even if the liquid CO₂ cylinder is full. Also, degradation of the battery shortens the cooling duration. The duration of time for which a full 30 kg liquid CO₂ cylinder can keep the chamber at -70°C varies depending on the size of the freezer and the volume of samples in the chamber. The following graphs show examples of the duration.

[Example] Duration of time for which a full 30 kg liquid CO₂ cylinder can keep the chamber at -70°C (no load)

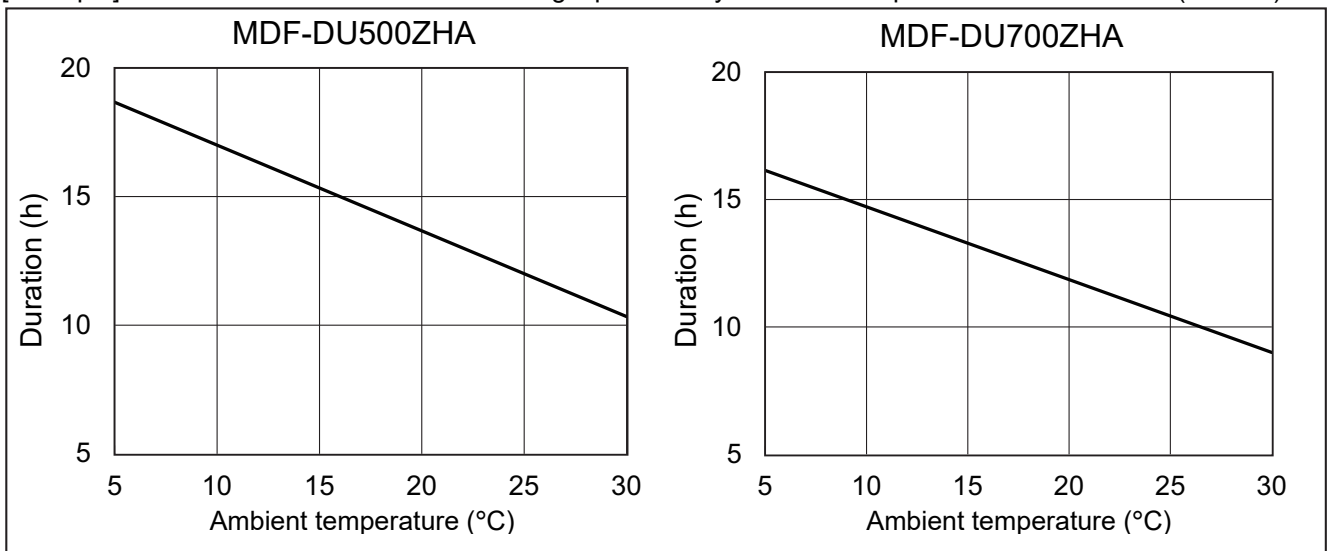

Notes:

- If the backup cooling system is used in a small room, or many freezers with backup cooling system are in a same room, a large amount of CO₂ gas is injected or released in the room. This may cause oxygen lack temporarily. For safety operation, install an alarm sensor and a ventilation device.
- Injecting liquid CO₂ into the chamber decreases pH in the chamber. Therefore, care should be taken for the samples that may be affected.

In the event of emergency

When a warning, alarm, or notice message appears at the message display area on the top screen (page 22), determine the cause of the situation by referring to pages 46 and 47. If the temperature in the freezer has risen, take the following measures.

- Make sure to determine the cause of the temperature rise.

The alarm status continues until the temperature in the chamber falls below the high alarm temperature. If the alarm status continues for more than an hour, or the chamber temperature does not fall, the freezer may be malfunctioning. Move the samples into a different freezer immediately and contact our sales representative or agent.

If there are no other ultra-low temperature freezers, protect your samples using the backup cooling system or dry ice.

- In the event of a power failure, check the duration and take alternate measures to cool the samples. If the power failure is expected to continue for several hours, protect your samples using the backup cooling system or dry ice.

- Amount of dry ice

To keep MDF-DU500ZHA (inner capacity: 525 L) to -70°C , firstly, put at least 25 kg of dry ice into the chamber. Then, add 2.5 kg of dry ice every hour. Wrap dry ice with paper such as newspaper and put it on each shelf equally.

To keep MDF-DU700ZHA (inner capacity: 725 L) to -70°C , firstly, put at least 35 kg of dry ice into the chamber. Then, add 3.5 kg of dry ice every hour. Wrap dry ice with paper such as newspaper and put it on each shelf equally.

Note:

The CO_2 gas concentration in the chamber becomes high after the sublimation of the dry ice. The pH of the water solution that does not include buffer solution may become lower if it is left under such an atmosphere for a long time.

[Example] Characteristics of chamber temperature rise during power failure (no load)

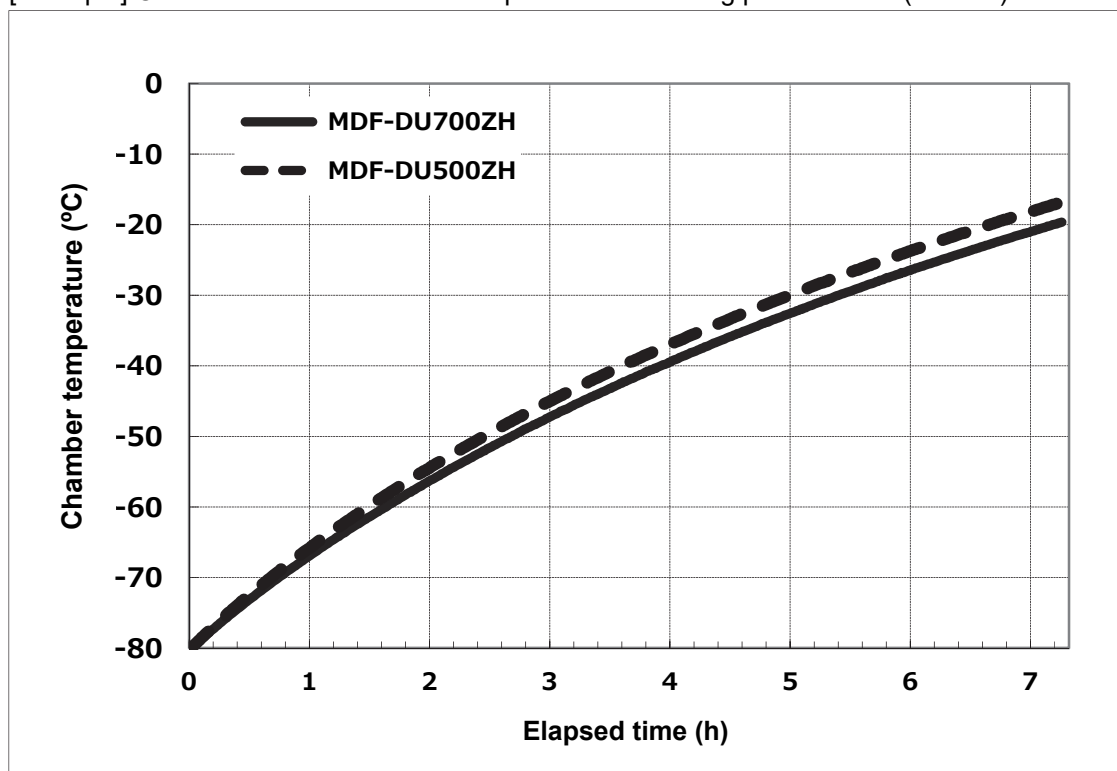

INSTALLATION SITE

To run the freezer unit properly, the unit must be installed in a location which meets all the conditions described below. If the location does not meet these conditions, the specified performance of the unit may not be achieved or malfunctions and accidents may occur.

■ **A location not exposed to direct sunlight**

Avoid any location which is exposed to direct sunlight. Installing the unit in a location exposed to direct sunlight may degrade its cooling performance.

■ **A well-ventilated (airy) location**

In order to ensure ventilation, leave clearances of at least 10 cm around the unit (at the left, right, top and back). Blocking the ventilation may degrade the unit's cooling performance or cause the unit to malfunction. Also, when installing multiple freezers back to back, leave clearances between them by considering the exhaust heat from the freezers.

■ **A location away from heat sources**

Avoid any location which is close to a major source of heat (such as a heater or boiler). Installing the unit near a major source of heat may degrade the unit's cooling performance.

■ **A location with minimal changes in temperature**

Avoid any location where the ambient temperature is subject to sudden changes. If the unit is installed in such a location, stable cooling performance may not be achieved. The ambient temperature range (environmental condition) for using this product is 5°C to 30°C.

■ **A firm and level location where the floor can bear the total combined weight (product + optional accessories + stored items)**

Install the unit on a level surface which is capable of bearing the total combined weight (product + optional accessories + stored items). If the unit is installed in a location where the floor surface is uneven or where the unit will be inclined at an angle, the unit will be unstable, and accidents or injuries may occur and/or unnecessary vibration or noise may be generated.

■ **A location with minimal humidity**

Install the unit in a location where the relative humidity is 80% RH or lower. Installing the unit in a very humid location may cause earth faults and/or electric shock.

■ **A location free of flammable or corrosive gases**

Avoid any location exposed to flammable or corrosive gases. Flammable or corrosive gases can cause explosions and/or a fire. Furthermore, corrosion of the electrical parts may cause the insulation to be deteriorated and result in earth faults and/or electric shock.

■ **A location where corrosive materials are not generated**

Never install the unit in a location where corrosive materials such as sulphur compounds are likely to be generated (e.g. near a drainage facility). Corrosion of the copper pipes may result in the deterioration of the cooling unit, or corrosion of electric components may lead to the failure of the product.

■ **A location where nothing can fall onto the unit**

Avoid locations where objects may fall onto the unit. Objects falling and hitting the unit may cause it to break down or fail.

Note:

Keep electric products which emit electromagnetic waves away from the unit. A noise from the electromagnetic waves may cause the unit to malfunction.

INSTALLATION

When installing the unit, follow the steps below to secure the unit properly.

1. Preparations after unpacking

Remove all the tape used to secure the doors and interior parts, and leave the doors open for a short while for ventilation. If any outer surfaces of the freezer are dirty, wipe the surfaces using a cloth moistened with a diluted neutral dish-washing detergent (using an undiluted solution of detergent may cause the unit's plastic areas to crack. Follow the directions on the detergent for details of dilution).

After wiping the unit using the diluted detergent, be sure to wipe the surfaces with a cloth dipped in clean water to remove traces of the detergent. After this, be sure to wipe the surfaces with a dry cloth, allowing the outer surfaces of the freezer to dry out completely, and then proceed with the installation.

Note:

Remove the cable tie that bands the power supply cord. Prolonged contact with the tie may cause corrosion of the cord coating.

2. Securing and leveling the unit using the leveling feet

Rotate the front leveling feet clockwise until the casters are raised 5 mm to 10 mm above the floor surface (Fig. 1).

Then, rotate the leveling feet slightly clockwise or anticlockwise to adjust them so that the unit is completely level.

- The unit becomes stable with the casters not contacting the floor. If the casters are left in contact with the floor, the unit may accidentally move when its door is opened or closed.

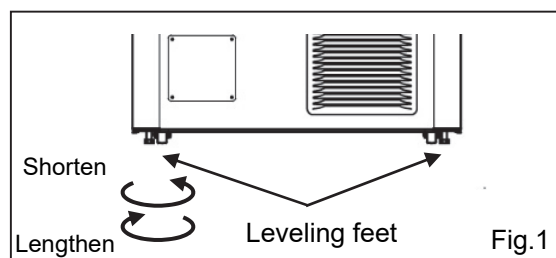

Fig. 1

3. Securing the unit using fixtures

Use the fixtures on the back panel of the unit, and secure the unit to the wall by passing a strong rope or chain through the fixtures (Fig. 2).

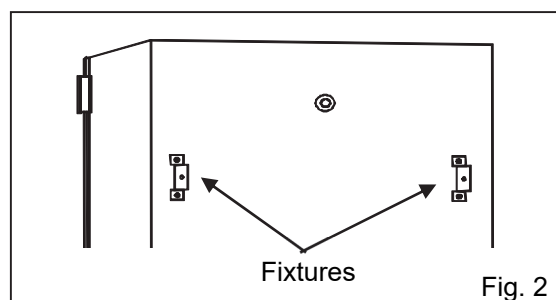

Fig. 2

4. Preventing electric shock by earthing the unit

When installing the unit, be sure to earth (ground) it. Earthing is necessary to prevent electric shock resulting from deterioration of electrical insulations.

- This unit comes with a power plug having one earth pin. Earthing work is not required in the case of a power outlet equipped with an earth contact.
- If the power outlet is not equipped with an earth contact, ask a qualified contractor to do the earthing work.

5. Setting up the shelves

Insert the shelf stoppers into the bores of the pilasters at the desired level and set the shelf firmly on the shelf stoppers (Fig. 3).

When using the optional inventory racks, insert the shelf stoppers into the bores at the positions of the pilasters described in "SETTING OF SHELF STOPPERS WHEN USING INVENTORY RACKS (page 56)" and set the shelves on the shelf stoppers.

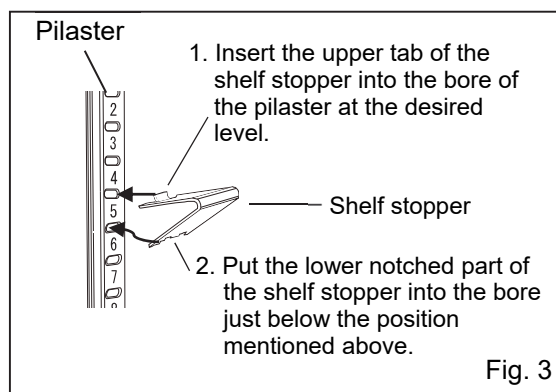
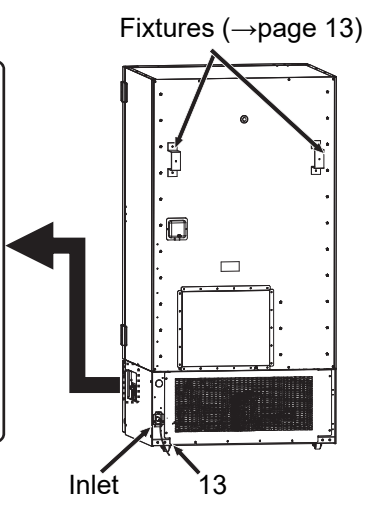
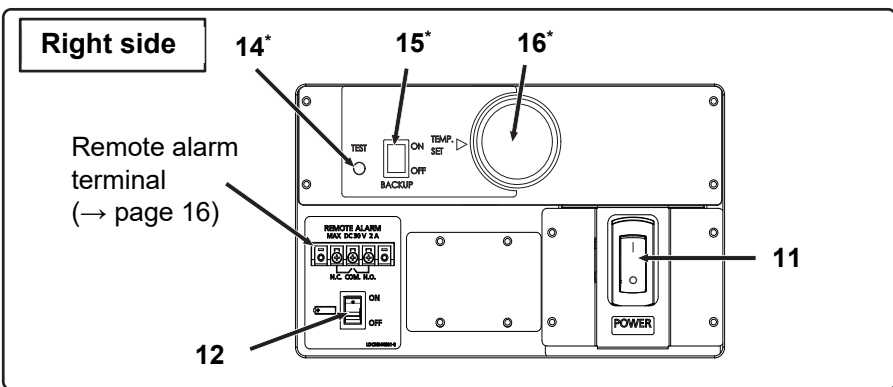
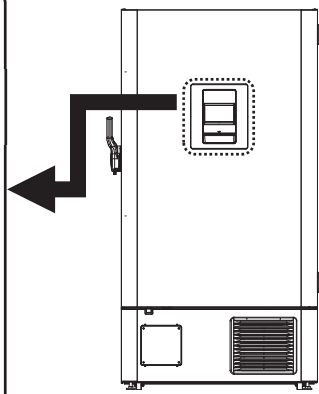
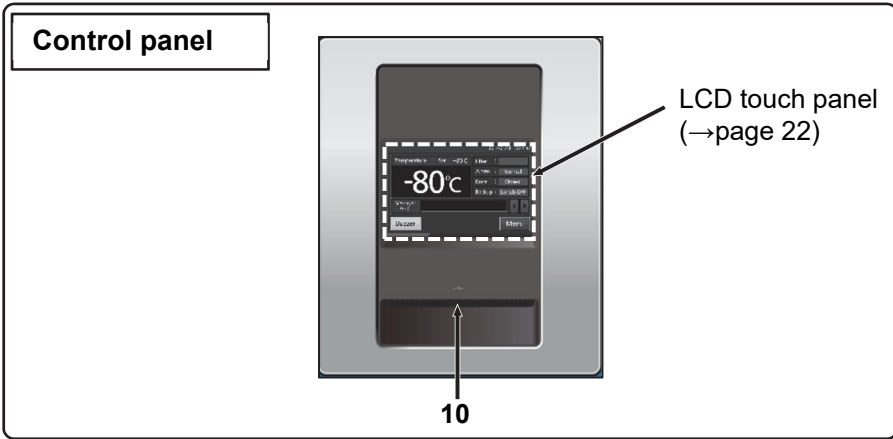
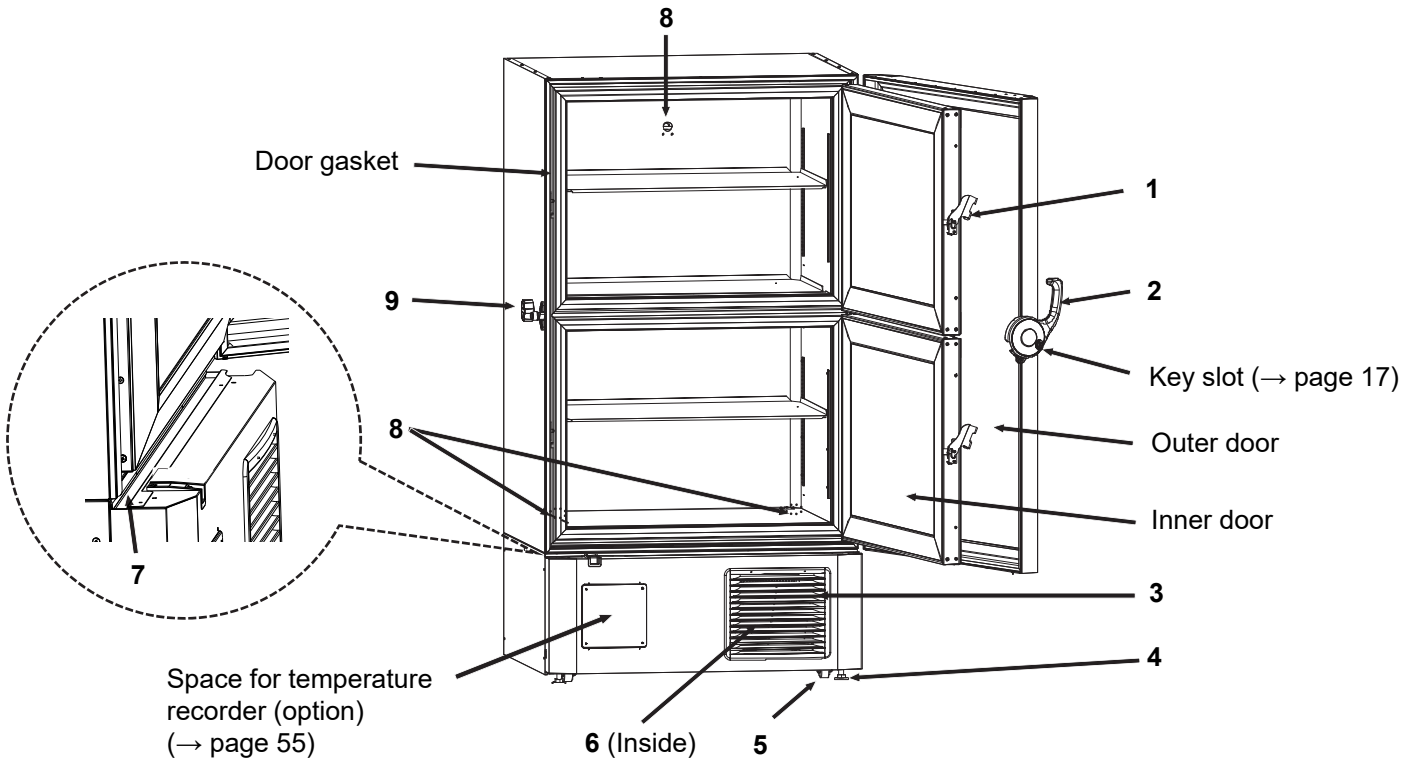

Fig. 3

FREEZER COMPONENTS

Main body

The model below shows MDF-DU700ZHA (MDF-DU500ZHA also has an equivalent structure).



* When the optional backup cooling system is installed.

1. Inner door latch: The inner door can be securely closed using this inner door latch. When closing the inner door, make sure to engage the latch. Otherwise, the samples in the chamber may be damaged due to the temperature changes in the chamber.

Note: When you try to open the inner door right after you close it, the inner door becomes hard to open due to the difference in pressure inside and outside of the inner door. Do not open the inner door by force. Opening the inner door by force may damage the inner door latch or cause injuries. In such a case, make sure to open the air intake port and let the air into the chamber, and then open the door (page 17).

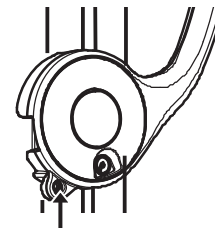

Padlock position

2. Outer door handle: Used for opening and closing the outer door. The latch is provided at the bottom of the handle for securely closing the outer door. When closing the outer door, grab the handle firmly and push it towards the cabinet side to engage the latch. Otherwise, samples in the chamber may be damaged due to the temperature changes in the chamber. When opening the outer door, grab the handle firmly and pull it towards you. At the latch part, the hole for a commercially available padlock is also provided.

3. Grille (air intake vent): The outer air is taken into the chamber from this vent. Do not block this vent. If the vent is blocked, the cooling performance of the freezer deteriorates.

4. Leveling feet: These are screw bolts used to secure and level the unit. Adjust the height of the leveling feet by turning them until the two front casters are away from the floor (page 13).

5. Caster: Four casters are provided to facilitate moving of the freezer. For the installation, adjust the leveling feet so that the two front casters cannot contact the floor.

6. Condenser filter (behind the grille): Prevents the dust from accumulating on the condenser. A dusty condenser filter may cause a failure of the freezer. Clean the condenser filter once a month (page 49).

7. Droplet catcher: Receives water droplets generated by the condensation formed on the inner door. Dry the catcher with a soft cloth.

8. Access ports (rear and bottom): Used to route the sensor/cable of measuring equipment, the sensor of the temperature recorder (optional), or the nozzle of the backup cooling system (optional) into the chamber.

Note: Be sure to put back the cap and insulation for the access ports after using the access ports. If they are not attached properly, the chamber temperature may not reduce, or condensation may occur outside the access ports.

9. Air intake port: From this port, the air is taken into the chamber to relieve the difference in pressure inside and outside of the chamber so that the door can be opened easily (page 17).

10. USB port: A USB flash drive is inserted here when exporting log data.

Note: USB flash drives with a capacity of 32 GB or less that employ the FAT16/FAT32 file system are supported. USB flash drives that require passwords cannot be used. We do not guarantee the correct operation of all USB flash drives even if these conditions are satisfied. Do not insert devices other than USB flash drives into the USB port.

11. Power switch: Power switch for the freezer unit (ON="I", OFF="O").

12. Battery switch for power failure alarm: Switch for turning ON/OFF the battery for power failure alarm. Always turn this switch on when the unit is operating to ensure that the power failure alarm is working. Turn this switch off when the unit is not used for a long period.

13. Power supply cord (detachable): Do not disconnect the power supply plug or the product side plug (inlet part) carelessly. If the power supply cord is disconnected, the contents of the chamber may be deteriorated.

* When the optional backup cooling system is installed:

14. Backup test switch (TEST)*: Used to check that the backup cooling system can inject liquid CO₂ (page 55).

15. Backup power switch (BACKUP)*: Power switch for the backup cooling system (page 55).

16. Temperature setting knob (TEMP. SET)*: Used to set the injection start temperature of the backup cooling system (page 55).

FREEZER COMPONENTS

Accessories

Check that following accessories are included with this unit. If any accessories are missing, contact our sales representative or agent.

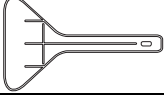
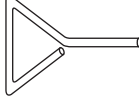
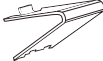
Name	Qty	Appearance	Usage
Key	1 set		For locking and unlocking the outer door (page 17).
Scraper	1		For removing frost in the chamber (page 50).
Stick for air intake port cleaning	1		For removing the frost in the air intake port (page 50).
Shelf stopper	8		For securing the shelves in the chamber (page 13).

Remote alarm terminals

The alarm condition of the freezer can be transferred to a remote location by connecting an external alarm device (commercially available) to the remote alarm terminals. Especially, the use of the remote alarm device is recommended if the freezer is placed in an unattended environment to ensure that alarm condition is notified to the administrator. For installing the alarm device, contact our sales representative or agent.

The terminals for the remote alarm are provided at the right side of the unit (see the right figure). Alarm signals are transmitted from these terminals as non-voltage contact outputs. Contact capacity is DC 30 V, 2 A.

Table 1 shows the terminal status and the behavior of the remote alarm when the Buzzer button is tapped.

Note:

- For the door alarm, remote alarm function does not activate (page 46).

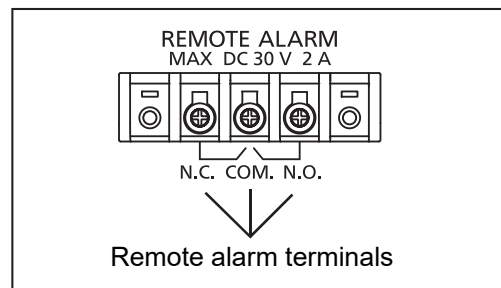

Table 1 Terminal status and behavior of remote alarm when Buzzer button is tapped

"Remote Alarm" setting (page 26)	Connection terminal	Normal condition	Abnormal condition (Including in the event of power outage and when power plug is pulled out.)	
			When Buzzer button is tapped	
ON: Not linked with Buzzer button	COM.-N.C.	Close	Open	Open (indicates abnormal condition)
	COM.-N.O.	Open	Close	Close (indicates abnormal condition)
OFF: Linked with Buzzer button	COM.-N.C.	Close	Open	Close (goes back to normal condition)
	COM.-N.O.	Open	Close	Open (goes back to normal condition)

Notes:

- For the types of alarms that can be transferred to the remote alarm device, refer to page 46.
- Use a commercially available alarm device when using the remote alarm function. Making a new device or remaking an existing device yourself may cause an electric shock or malfunction.
- When connecting an alarm device to the remote alarm terminals, turn off the power switch and unplug the freezer. Otherwise, it may cause an electric shock.
- Use shielded wire for connection. A maximum length of 30 meters of the cable is recommended.

Locking/unlocking the outer door

The outer door can be locked using the accessory key and the lock system at the bottom of the outer door handle.

1. Locking the door

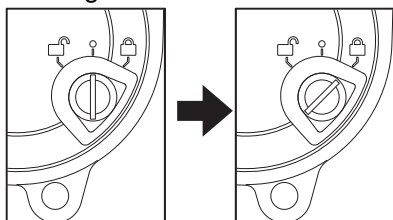

Insert the key into the key slot and turn it 45 degrees clockwise (to the position marked with ). After the door is locked, turn the key back to the first position and take it out of the lock system.

2. Unlocking the door

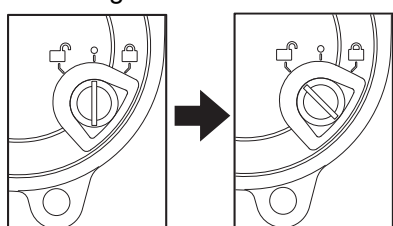

Insert the key into the key slot and turn it 45 degrees counterclockwise (to the position marked with ). After the door is unlocked, turn the key back to the first position and take it out of the lock system.

Notes:

- After locking/unlocking the door, be sure to take the key out of the key slot and store and manage it in a safe place.
- If the key is lost, contact our sales representative or agent and provide the number stamped in the metal near the key slot.

Air intake port

The pressure difference between inside and outside of the chamber can be adjusted for the smooth opening of the inner door.

When the inner door is heavy, and it is hard to open the door, follow the procedure below.

1. Turn the cap on the left side counterclockwise about two turns (or remove the cap).
2. Allow about twenty seconds, and then open the inner door.
3. After the door operation, put the cap back and screw it tightly.

Note:

When excessive frost has built up in the air intake port, the inner door may be hard to open even after the above procedure is taken. In such a case, check for frost accumulation inside the air intake port by removing the cap on the air intake port.

If excessive frost has built up in the air intake port, remove the frost using the "stick for air intake port cleaning" [page 50].

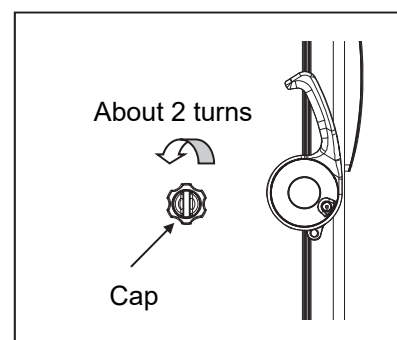

START-UP PROCEDURE

Follow the procedure below to start test run or start operation of this product.

Preparation

1. Check that the following switches at the lower right side of the unit are turned off: power switch, battery switch for power failure alarm, backup power switch (if the optional backup cooling system is installed).

Note: Power failure alarm will activate if the battery switch for power failure alarm is turned on when the power to the freezer is off.

Start-up

2. Without putting anything into the chamber, connect the power supply cord to the dedicated outlet.

3. Turn on the power switch for the unit to start freezer operation.

Setting after start-up

4. Turn on the battery switch for power failure alarm.

Note: When the battery switch for power failure alarm is OFF, the message "S20: Battery Inactive, SW may be OFF." is displayed in the message display area. This message disappears when the battery switch for power failure alarm is turned ON.

5. Set the desired chamber temperature set point and high and low temperature alarms (page 24).

Note: Keep the ambient temperature 5°C to 30°C. The chamber temperature may not reach to the set point if the ambient temperature exceeds 30°C.

Check

6. Check that the chamber temperature has cooled to the set point by looking at the temperature displayed on the Top screen.

7. Perform the alarm test. Check that the alarm activates properly by following the instruction about alarm test on page 26.

Setting optional device function

8. Turn on the backup power switch (BACKUP) for the optional backup cooling system (if installed).

Note: When backup power switch is off, "Switch OFF" is displayed in the backup status indicator on the Top screen. The indication changes to "Switch ON" when the backup power switch is turned on.

9. Press the backup test switch (TEST) for the optional backup cooling system (if installed) to check if it works properly (you can hear a slight injection sound).

Note: If the backup cooling system is not charged enough when this product is turned on for the first time or this product is not used for a long time, the backup cooling system may not work properly. In this case, charge the backup cooling system by running the freezer for more than 6 hours. For fully charging the completely discharged backup cooling system, the freezer should run more than three days.

10. Set the injection start temperature of the backup cooling system (if installed) using the temperature setting knob (TEMP.SET).

11. Put the samples into the chamber little by little.

- ◆ Putting a large volume of samples into the chamber at a time causes the temperature to rise rapidly.
- ◆ Putting too many high-temperature items into the chamber may raise the chamber temperature, causing the samples to deteriorate.

12. Configure settings (alarm setting, key lock setting, etc.) as necessary.

Notes:

- When closing the inner/outer door, push the inner door latch/outer door handle towards the cabinet side until the latch is engaged. Insufficient pushing can cause temperature rise in the chamber.
- If some optional inventory racks are in the chamber, be careful not to drop inventory rack when pulling it out.

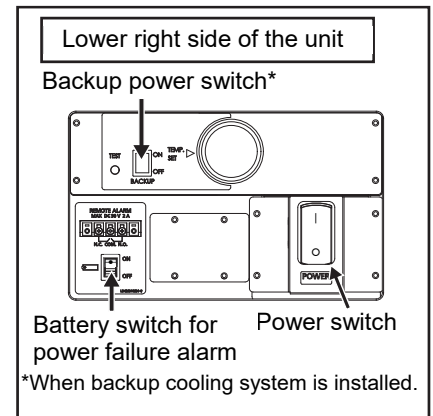

DURING/AFTER POWER FAILURE

Operation during power failure

When the battery switch for power failure alarm is ON, the unit behaves as follows even during a power failure.

- The power failure alarm activates (page 46).*
Tap the Buzzer button to silence the sound of the power failure alarm. If the ring back function is turned ON, the audible alarm sounds again when the power failure still continues after the set ring back time has elapsed (page 25).
- LCD touch panel becomes dark.
By touching the LCD touch panel, it becomes brighter for 5 seconds.*
- The High/Low alarm can activate even during a power failure (pages 22, 24, and 46).*
When High/Low alarm activates, the message indicating the situation is displayed on the message display area. At this point, the audible alarm and the remote alarm have activated and the alarm condition is displayed on the Alarm indicator since the power failure alarm has already activated.
- The clock does not stop.
- Recording of the operation logs and alarm logs continues during a power failure.*

*When the battery is flat, these functions do not work.

Operation after recovery from power failure

During a power failure, the setting values are stored in the nonvolatile memory. Therefore, after the power comes back, the freezer resumes the operation using the setting values before the power failure. Reconfiguration for setting values is not required but check the settings such as operation settings and alarm settings. If the settings have been changed for some reasons, stored items inside the unit may be adversely affected after the operation resumes.

“Alarm” is displayed alternately in normal and reverse video.

In order to notify the user that a power failure has occurred, the alarm status continues even if the freezer resumes its operation after the power failure. That is, the audible alarm sounds and “Alarm” is displayed alternately in normal and reverse video in the alarm indicator. Tapping the Buzzer button stops the sound and changes the indication in the alarm indicator to “Normal.” Also, you can check whether a power failure has occurred or not, by referring to the alarm log (page 41).

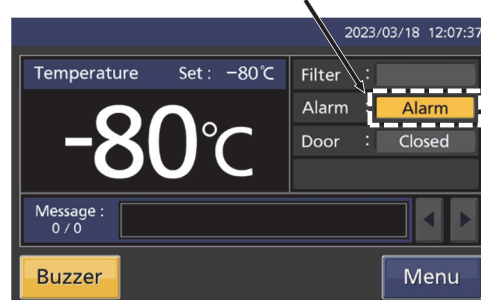

Notes:

- In case of power failure, take appropriate measures to protect the valuable samples following the tips described on pages 10 and 11.
- It may take up to 1 minute until the LCD touch panel turns on after the power comes back.
- If multiple freezers are used, all of the freezers will start up at the same time after the power comes back. This will lead to a temporary voltage drop and may affect the starting of the freezers. To prevent this situation, set the appropriate compressor delay time for the freezers (page 27).

2. TOUCH PANEL OPERATION

USING THE TOUCH PANEL

For controlling the freezer, the LCD touch panel is provided at the front of the freezer.

Basic Operation

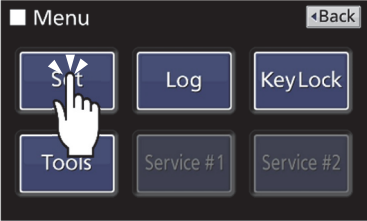
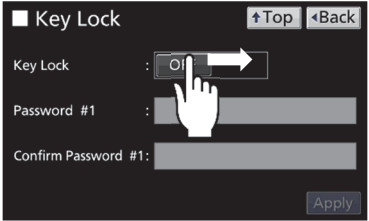
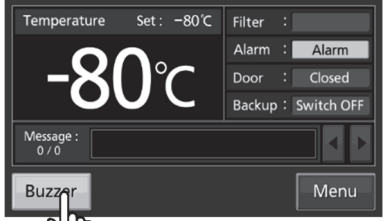
Tap Lightly touch the screen with your finger and immediately release the finger from the screen.	Slide With lightly touching the screen with your finger, move to the destination and then release the finger from the screen.	Long tap Lightly touch the screen for a few seconds and then release the finger from the screen.
		

Notes:

- Use your finger or a stylus pen to protect the screen.
- Do not use sharp pointed hard items such as the tip of a ballpoint pen for touching the screen.

Entering alphanumeric values and symbols

Entering numerical values:

1. Tap the numeric input field.
▶ The numeric input window is displayed.

Numeric input fields

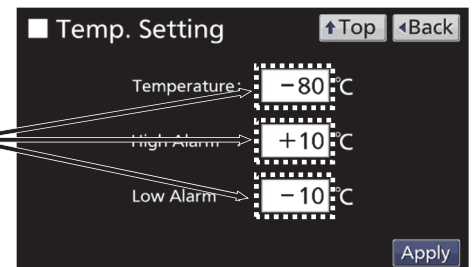

2. Tap the numeric keys or Up/Down keys to enter a numerical value.

Details of keys in the numeric input window

- Numeric keys (0~9): Input numbers directly.
- Up/Down keys (▲/▼): Increase or decrease the numerical value displayed in the numeric input field.
- Clear button: Deletes the numerical value displayed on the numeric input box.

Note:

∞, +, and - keys are unavailable.

3. Tap the OK button.

Note:

In some situations, the Up/Down keys are not displayed.

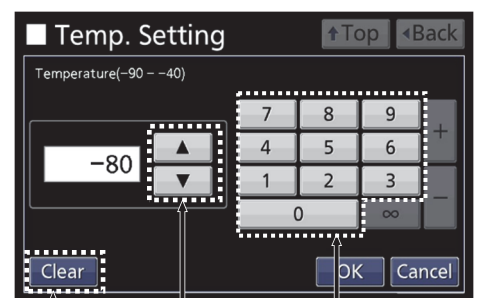

Clear button Up/Down keys Numeric keys

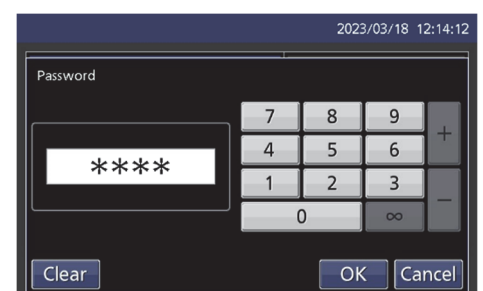

Entering alphanumeric characters and symbols:

1. Tap the alphanumeric input field.
▶ The alphanumeric input window is displayed.

Alphanumeric input field

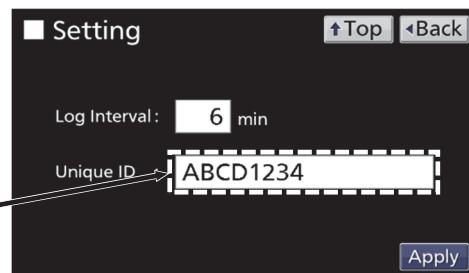

2. Tap the alphabetic keys, numeric keys, or symbol keys to enter alphanumeric characters and symbols.
*You can switch the uppercase letters/numbers window to lower case letters/symbols window by tapping the **A↔a** button. The screen switches in the order of the uppercase letters/numbers window → lowercase letters/symbols window.

Details of keys in the alphanumeric input window

- Alphabetic keys (A to Z, a to z, Space): Input alphabetic characters or spaces.
- Numeric keys (0 to 9): Input numbers.
- Symbol keys: Input symbols
- Left/Right buttons (◀/▶): Move the cursor to the left/right.
- Delete button: Deletes an alphanumeric character or symbol immediately to the left of the cursor.

3. Tap the OK button.

Note:

While the alphanumeric input window is open, the Top button and the Back button are unavailable.

[Uppercase letters, numbers]



[Lowercase letters, symbols]



Other operations

1. Common button operation on the touch panel:

Button	Name/Details
	OK button Confirm the selected setting and return to the previous screen (the setting has not been saved yet).
	Cancel button Cancel the selected setting and return to the previous screen.
	Apply button Apply and save the setting into the unit and return to the previous screen.
*	Top button Return to the Top screen.
*	Back button Return to the previous screen.

* If you tap these buttons on the screens for selecting/setting values before tapping the Apply button, the values are not saved into the unit.

2. Auto return function

When there is no touch panel operation for about 90 seconds on screens other than the Top screen, the display automatically returns to the Top screen. Therefore, when you are in the middle of setting some values and do not touch the screen for more than about 90 seconds, the screen returns to the Top screen without saving the data.

When the sleep function is set to ON and there is no touch panel operation for about 90 seconds without any alarm or error in the sleep state, the display automatically returns to the Top screen.

TOP SCREEN

The following screen is displayed on the LCD display after turning on the power switch for the freezer. This screen is called as “Top screen” and shows basic information about the status of the freezer. It will take about 20 seconds before the Top screen is displayed after turning on the power switch.

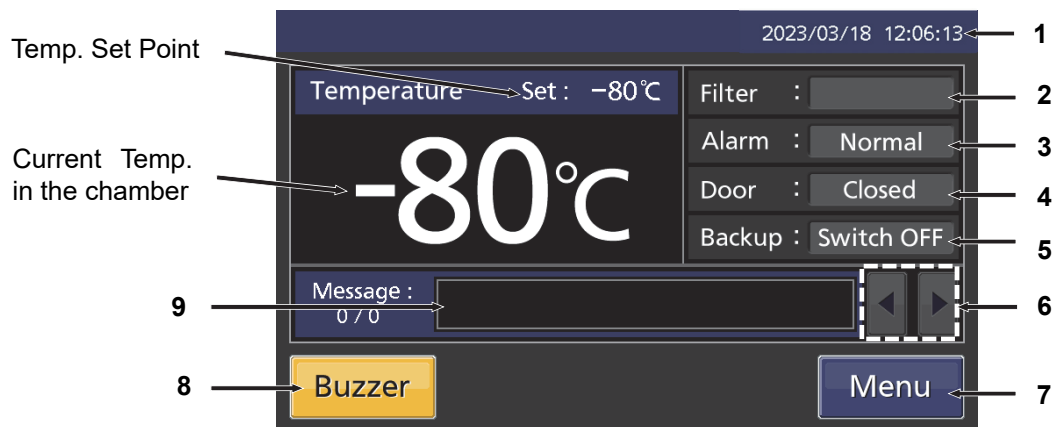

1. Current date/time: Current date and time is displayed here. The date and time has been temporarily set at the factory. For details about setting the date and time, refer to page 32.

2. Filter alarm indicator: This indicator turns orange when excessive dust is accumulated on the condenser filter. When this indicator turns orange, clean the condenser filter by following the procedure on page 49.

Note:

The indicator may turn orange when the ambient temperature is high, or during the period from turning on the power switch to the time chamber temperature reaches the temperature set point.

3. Alarm indicator

Indicates the alarm condition of the freezer. For details of the alarm delay time refer to page 25.

Normal condition:

“Normal” is displayed.

Alarm condition (during alarm delay time):

“Alarm” is displayed alternately in normal and reverse video.

Alarm condition (after alarm delay time):

“Warning” is displayed alternately in normal and reverse video.

For details of alarm types, refer to pages 46 and 47.

4. Door status (open/close) indicator:

Indicates the outer door open/close status.

Open: “Open” is displayed alternately in normal and reverse video.

Close: “Closed” is displayed.

5. Backup status indicator: (displayed only when the optional backup cooling system is installed)

ON/OFF status of the backup power switch is displayed [page 55].

ON: “Switch ON” is displayed.

OFF: “Switch OFF” is displayed.

Not installed: No indication.

6. Message selection button: When there are multiple messages relating to the warning, alarm, or the status of the freezer, tapping these buttons can switch to the previous or next message.

7. Menu button: Tapping this button displays the Menu screen where you can configure various settings [page 23].

8. Buzzer button: Tapping this button stops the audible alarm. However, when the ring back is ON, the audible alarm will sound again if the preset amount of time has elapsed after this button was tapped and the alarm condition still continues [pages 26 and 48].

9. Message display area: The warning, alarm, or the status of the freezer is displayed (pages 46 and 47).



MENU SCREEN

Tapping the Menu button on the Top screen displays the Menu screen where you can select one of the buttons for configuring setting or using log function (chart view or log data export).

<Top screen>

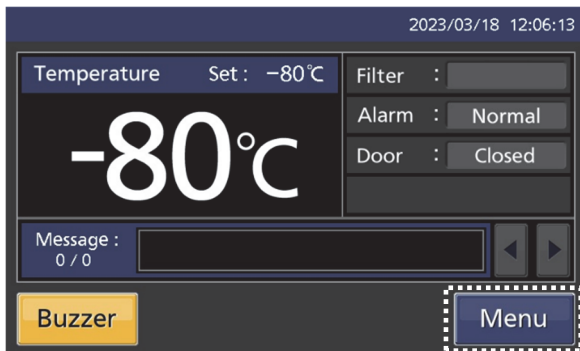

<Menu screen>

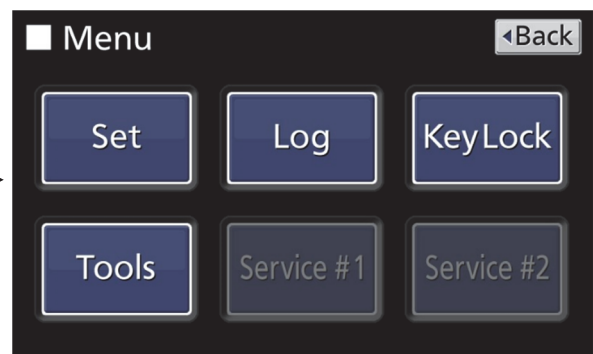

Buttons on the Menu screen

1. **Set button:** For setting temperature set point and high/low alarms (page 24).

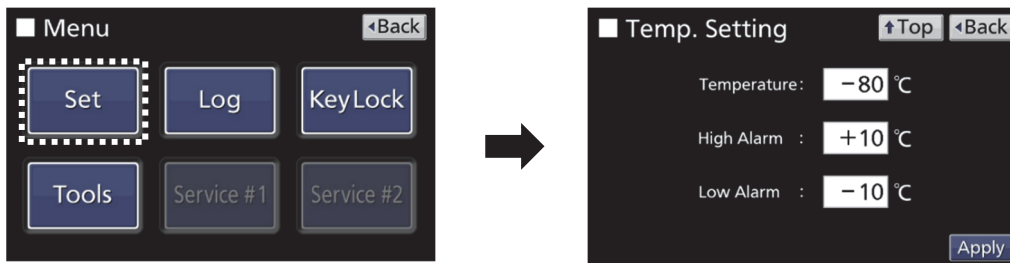

2. **Log button:** For viewing and exporting operation/alarm log (pages 35 to 45).

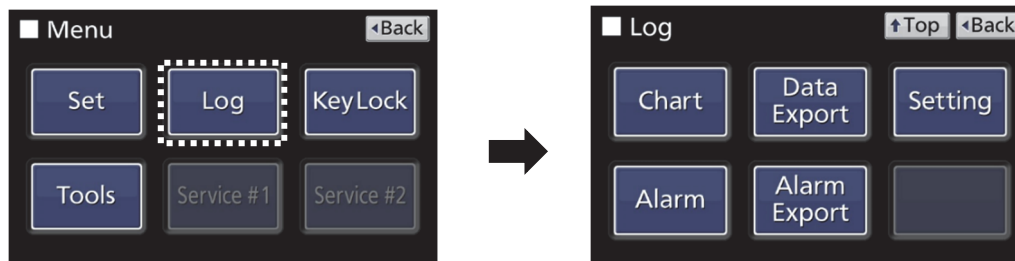

3. **Key Lock button:** For configuring the key lock setting (pages 28 to 31).

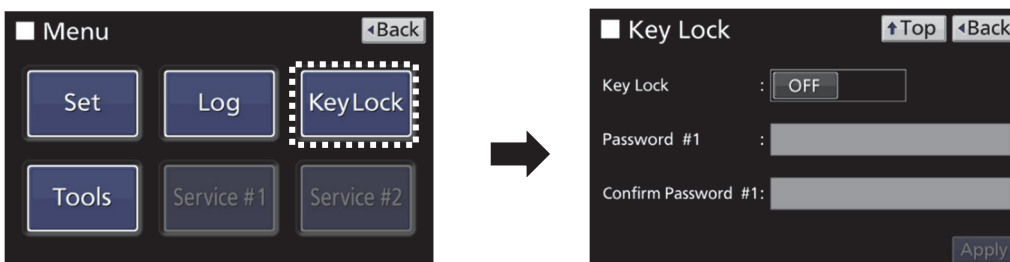

4. **Tools button:** For other settings such as compressor delay time and date and time (pages 25-27, 32-34).

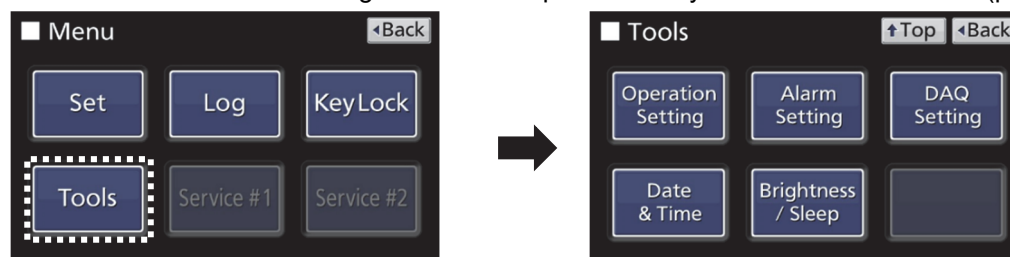

3. SETTINGS AND OPERATION

SETTING FOR BASIC OPERATION

Setting temperature and high/low alarms

The chamber temperature, high temperature alarm, and low temperature alarm can be set by following the steps below.

1. On the Top Screen, tap the Menu button.
▶ The Menu screen is displayed.

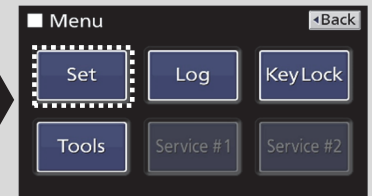
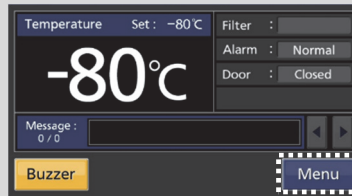

2. Tap the Set button on the Menu screen.
▶ The Temp. Setting screen is displayed.

3. Tap the numeric input field to enter each value.

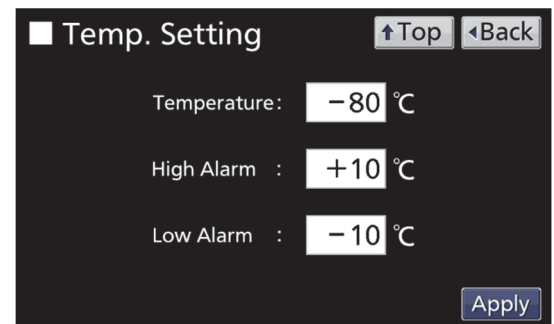

Details of entry

Item	Details	Settable range	Default value
Temperature	Temperature set point of the freezer.	-90°C to -40°C	-80°C
High Alarm	When the chamber temperature exceeds the temperature (value set to "Temperature" + value set to "High Alarm")*, the high alarm activates.	+5°C to +40°C	+10°C
Low Alarm	When the chamber temperature falls below the temperature (value set to "Temperature" - value set to "Low Alarm")*, the low alarm activates.	-40°C to -5°C	-10°C

* Since the chamber temperature displayed on the Top screen is the value rounded to the nearest integer, the high/low alarm may activate when the value of the displayed chamber temperature is equal to the set alarm temperature.

4. Tap the Apply button.
▶ The values are saved and the screen returns to the Menu screen.
5. Tap the Back button on the Menu screen.
▶ The screen returns to the Top screen.

Configuring alarm settings

On the Alarm Setting window, the alarm delay time, door delay time, ring back function, and remote alarm can be configured.

1. On the Top Screen, tap the Menu button.
▶ The Menu screen is displayed.

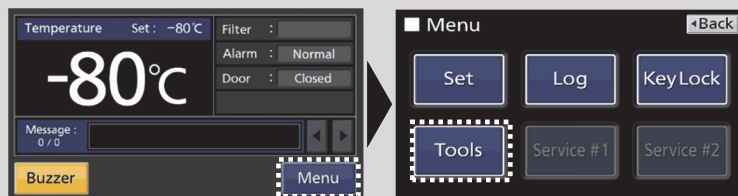

2. Tap the Tools button on the Menu screen.
▶ The Tools screen is displayed.

3. On the Tools screen, tap the Alarm Setting button.
▶ The Alarm Setting screen is displayed.

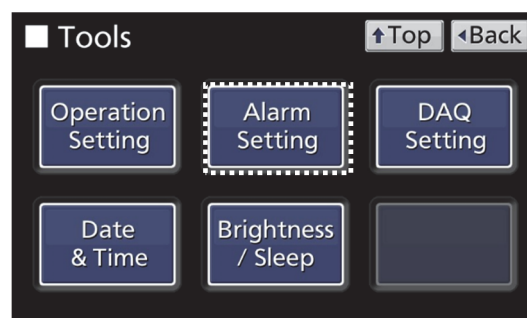

4. Tap the numeric input field to enter each value or slide the ON/OFF buttons to configure the settings.

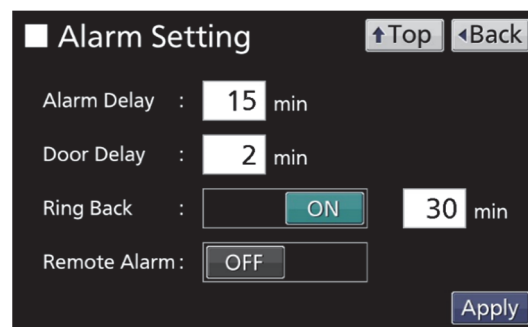

Details of entry

Item	Details	Settable range	Default value
Alarm Delay	Alarm delay is a function that when the High Alarm or Low Alarm status occurs, instead of activating audible alarm or remote alarm immediately, activates the alarm after the elapse of the set alarm delay time. Note: When the freezer recovers from the alarm status within the set alarm delay time, audible alarm or remote alarm does not activate after the elapse of the alarm delay time.	0 to 15 min	15 min
Door Delay	Door delay is a function that when the unit is in the door alarm (the outer door is open) status, instead of sounding immediately, the alarm will sound after the elapse of the set door delay time. Note: When the unit recovers from the alarm status within the set door alarm delay time, the door alarm does not activate after the elapse of the door alarm delay time.	0 to 15 min	2 min
Ring Back	Ring back is a function that the audible alarm sounds again when an alarm status still continues after the ring back set time elapsed even though the alarm sound was stopped by tapping the Buzzer button. The Ring Back can be turned ON/OFF by sliding the ON/OFF button. When turning it on, enter the ring back time in the right numeric input field. Note: For the door alarm, the alarm does not activate again since the door alarm itself is deactivated by tapping the Buzzer button (page 48).	ON/OFF 1 to 99 min	ON 30 min

SETTING FOR BASIC OPERATION

Item	Details	Settable range	Default value
Remote Alarm	<p>Selects behavior of the remote alarm when the Buzzer button is tapped to stop the audible alarm sound of the freezer unit. When "ON" (not linked with the Buzzer button) is selected by sliding the button to the right, the alarm indication by the remote alarm device does not stop even if the Buzzer button is tapped.</p> <p>ON: Not linked with the Buzzer button (remote alarm continues) OFF: Linked with the Buzzer button (remote alarm stops)</p>	ON/OFF	ON

5. Tap the Apply button.
 - ▶ The values are saved and the screen returns to the Tools screen.
6. Tap the Top button on the Tools screen.
 - ▶ The screen returns to the Top screen.

About alarm test

You can check if the alarm activates properly by long tapping the Buzzer button on the Top screen for about 5 seconds. When the alarm activates, the following alarm status can be observed.

- Audible alarm beeps.
- At the alarm indicator, "Test" is displayed alternately in normal and reverse video.
- Remote alarm activates (if installed).

The test alarm status is canceled by tapping the Buzzer button.

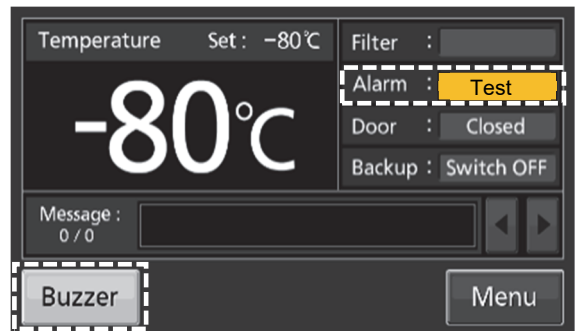
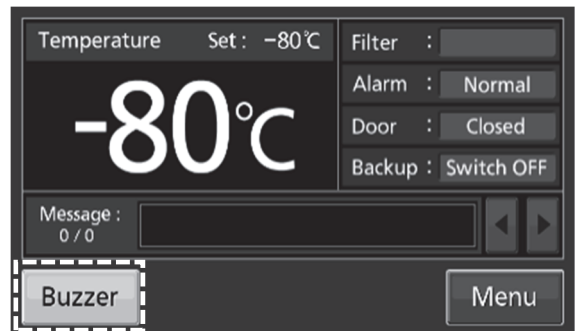

Setting compressor delay time

Compressor delay time is the time from when the freezer is turned ON or the power comes back in the event of a power failure until when the compressor starts up. This unit requires a large amount of electric power at the instant of compressor start-up. If multiple freezer units are installed in a same room, shift the start-up time of each compressor so that the compressors do not start up at the same time after a power failure.

1. On the Top Screen, tap the Menu button.
▶ The Menu screen is displayed.

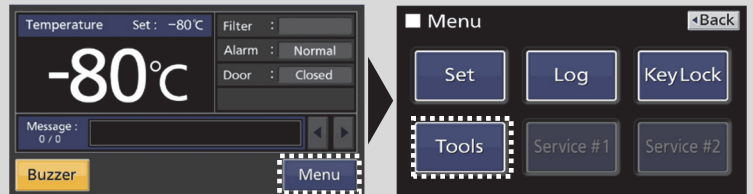

2. Tap the Tools button on the Menu screen.
▶ The Tools screen is displayed.

3. Tap the Operation Setting button on the Tools screen.
▶ The Operation Setting screen is displayed.

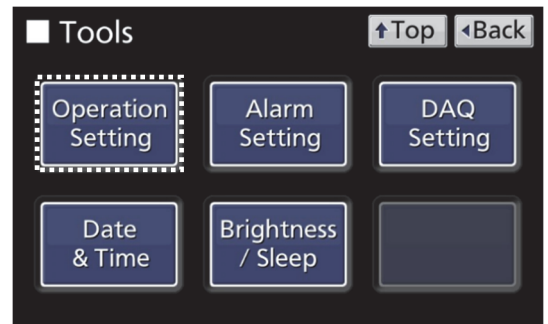

4. Tap the numeric input field for the Compressor Delay.
▶ The numeric input window is displayed.
Enter the compressor delay time.

Settable range: 3 to 15 minutes
Default value: 3 minutes

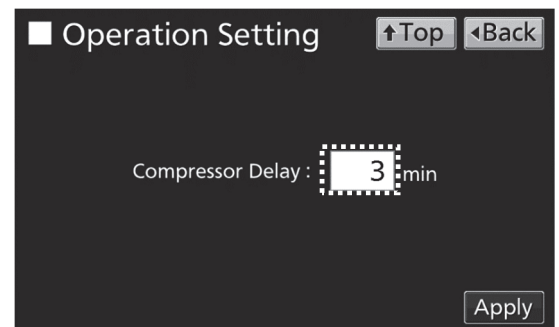

5. Tap the Apply button.
▶ The values are saved and the screen returns to the Tools screen.

6. Tap the Top button on the Tools screen.
▶ The screen returns to the Top screen.

KEY LOCK

Key lock function prevents unauthorized changes to the freezer setting by prompting the user to enter a password when the Menu button is tapped.

Setting key lock

The key lock function can be turned ON as follows.

1. On the Top Screen, tap the Menu button.
▶ The Menu screen is displayed.
2. Tap the Key Lock button on the Menu screen.
▶ The Key Lock screen is displayed.

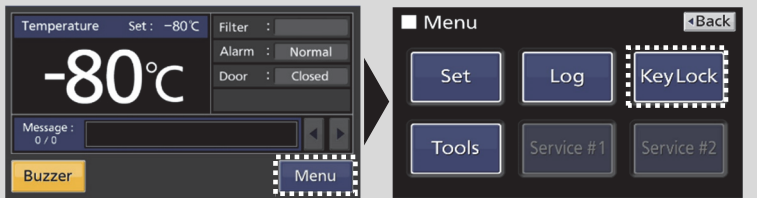

3. Configure the key lock settings.

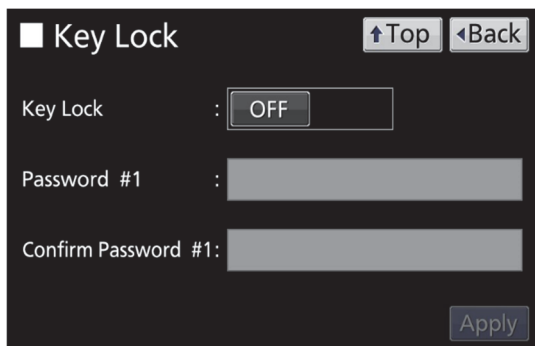

Details of entry

Item	Details	Settable range	Default value
Key Lock	Slide the slide button to turn ON or OFF the key lock function. To turn ON, slide the button to the right.	ON/OFF	OFF
Password #1	Enter a password to be used for unlocking the key lock. You can use a 1 to 6 digit number for the password. 1. Tap the Password #1 input field. ▶ The numeric input window is displayed. 2. Enter a 1 to 6 digit number and tap the OK button. ▶ The screen returns to the Key Lock screen.	1 to 6 digit number	-
Confirm Password #1	1. Tap the Confirm Password #1 input field. ▶ The numeric input window is displayed. 2. Enter the same password as "Password #1" and tap the OK button. ▶ The screen returns to the Key Lock screen. Note: If the password does not match the password entered in the Password #1 field, the following message is displayed. Tap the OK button and enter the same correct passwords in both input fields again.	1 to 6 digit number	-

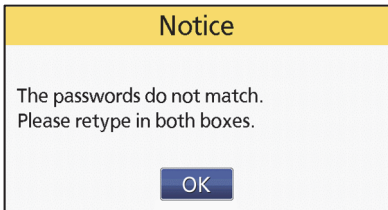

4. Tap the Apply button.

► The confirm message asking if you set the second password or not.

Yes: The Key Lock screen for setting the password #2 will be displayed.

→Proceed to Step 5.

No: The display returns to the Menu screen (in this case, only one password is registered).

→Proceed to Step 11.

Note:

You can set two different passwords. To release the key lock, enter either of the passwords.

5. Tap the Password #2 input field.

► The numeric input window is displayed.

6. Enter a 1 to 6 digit number and tap the OK button.

► The screen returns to the Key Lock screen.

7. Tap the Confirm Password #2 input field.

► The numeric input window is displayed.

8. Enter the same password as "Password #2" and tap the OK button.

► The screen returns to the Key Lock screen.

Note:

If the password does not match the password entered in the Password #2 field, the following message is displayed. Tap the OK button and enter the same correct passwords in both input fields again.

9. Tap the Apply button.

► The Information message that shows the Password #2 has been set.

10. Tap the OK button.

► The values are saved and the screen returns to the Menu screen.

11. Tap the Back button on the Menu screen.

► The screen returns to the Top screen.

Note:

Be sure to manage the passwords properly.

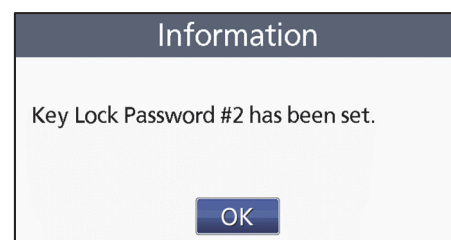
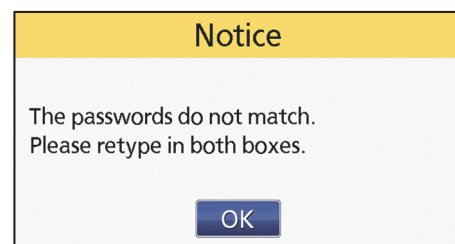
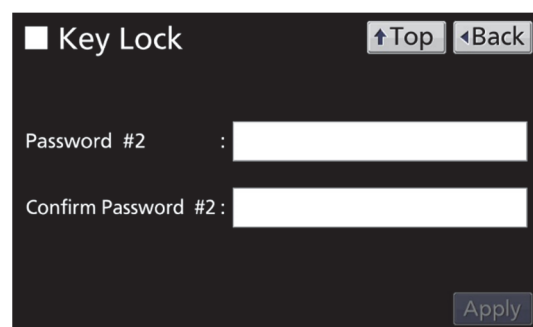
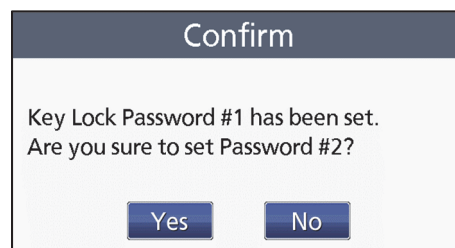

KEY LOCK

Operation when key lock is ON

When the key lock is set to ON, if you try to tap the Menu button on the Top screen, you are asked to enter a password.

1. On the Top screen, tap the Menu button.
▶ The Password input window is displayed.

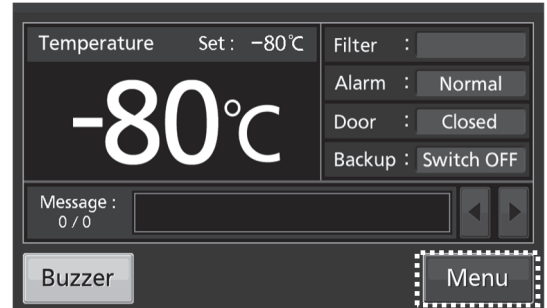

2. Enter the password and tap the OK button.
▶ The Menu screen is displayed.

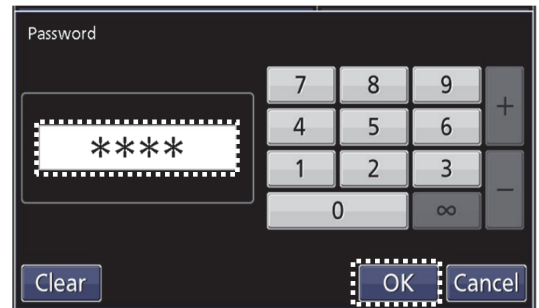

Notes:

- If two passwords are registered, you can release the lock by entering either of the passwords.
- When the password you entered is incorrect, the Notice message is displayed. Tap the OK button, and then enter a correct password.

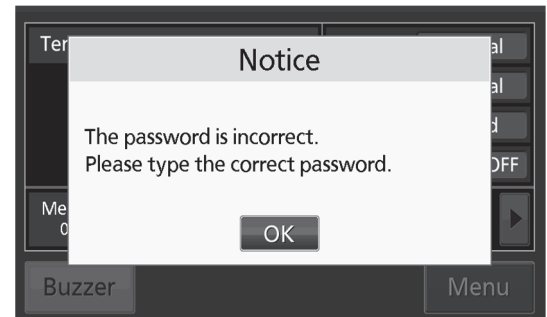

Cancelling key lock setting

You can turn off the key lock setting by following the steps below.

1. On the Top screen, tap the Menu button.
▶ The Password input window is displayed.

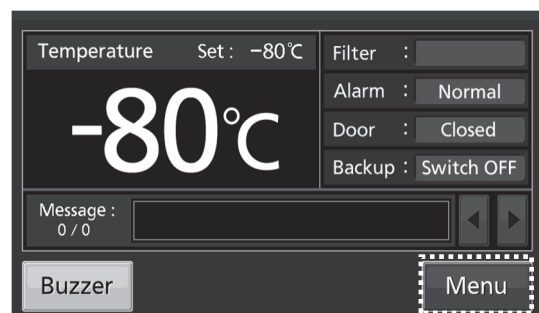

2. Enter the password and tap the OK button.
▶ The Menu screen is displayed.

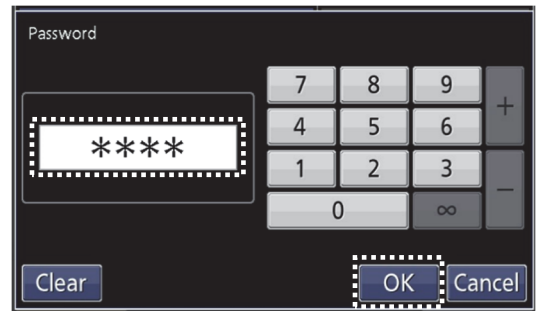

3. Tap the Key Lock button on the Menu screen.
▶ The Key Lock screen is displayed.

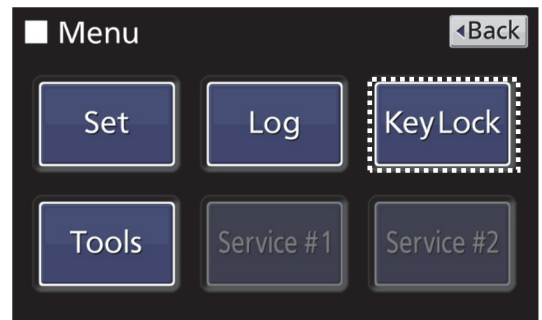

4. Slide the Key Lock slide button to the left.
▶ The key lock is set to OFF.

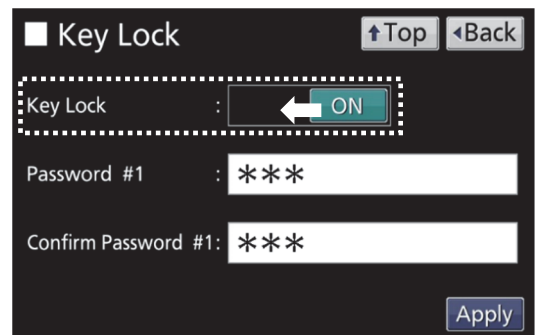

5. Tap the Apply button.
▶ The Information message showing that key lock has been canceled is displayed.

6. Tap the OK button.
▶ The setting is saved and the screen returns to the Menu screen.

Note:

The registered passwords are deleted.

7. Tap the Back button on the Menu screen.
▶ The screen returns to the Top screen.

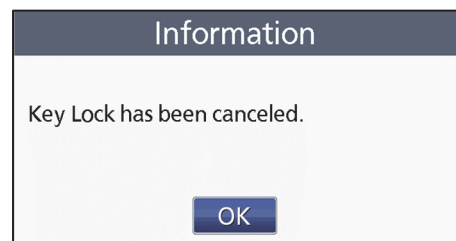

OTHER SETTINGS

Setting date and time

You can set date and time for the freezer.

1. On the Top Screen, tap the Menu button.
▶ The Menu screen is displayed.
2. Tap the Tools button on the Menu screen.
▶ The Tools screen is displayed.

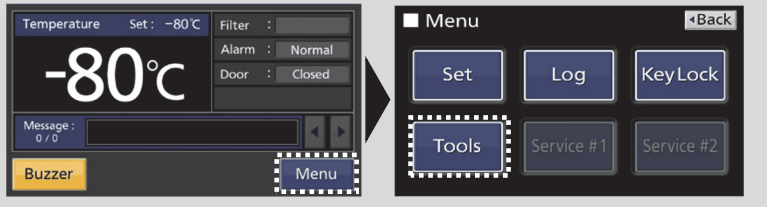

3. Tap the Date & Time button on the Tools screen.
▶ The Date & Time screen is displayed.

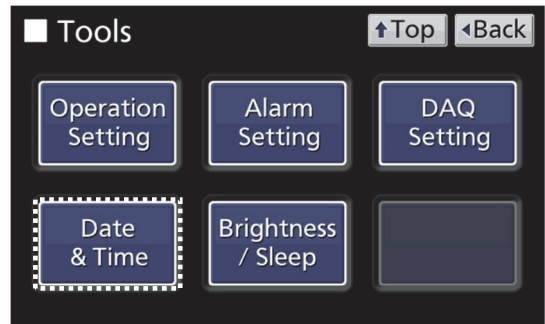

4. Configure the settings for date and time.

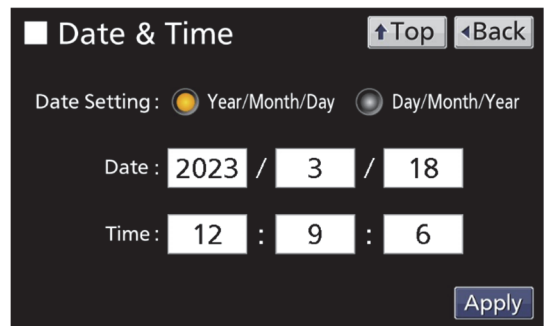

Details of entry

Item	Details	Settable range	Default value
Date Setting	Select the date format by tapping the radio button.	Year/Month/Day or Day/Month/Year	Year/Month/Day
Date	Enter the current date by tapping each input field and tapping the ▲/▼ buttons or numeric keys on the input window. Then, tap the OK button.	-	The date and time has been temporarily set at the factory. Set the correct date and time.
Time	Enter the current time by tapping each input field (hour: minute: second) and tapping the ▲/▼ buttons or numeric keys on the input window. Then, tap the OK button. The time is expressed using a 24-hour clock. Note: It is advisable to set the right time regularly since the error of about 1 minute may be observed within a month.	-	

5. Tap the Apply button.
▶ The values are saved and the screen returns to the Tools screen.
6. Tap the Top button on the Tools screen.
▶ The screen returns to the Top screen.

Setting brightness and sleep

You can configure the brightness of the LCD touch panel and the sleep function.

1. On the Top Screen, tap the Menu button.

▶ The Menu screen is displayed.

2. Tap the Tools button on the Menu screen.

▶ The Tools screen is displayed.

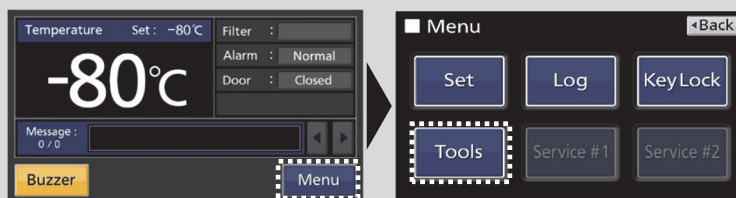

3. Tap the Brightness/Sleep button on the Tools screen.

▶ The Brightness/Sleep screen is displayed.

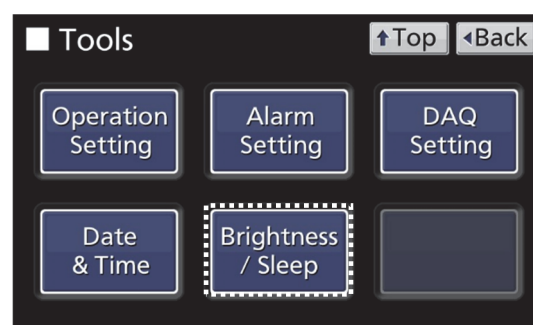

4. Configure each setting on the Brightness/Sleep screen.

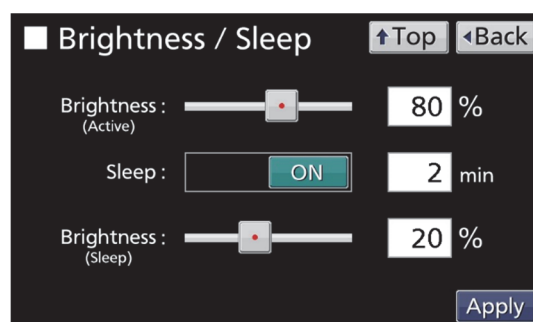

Details of entry

Item	Details	Settable range	Default value
Brightness (Active)	Brightness of the LCD touch panel in normal state. You can set the value using the slider bar or tapping the input field to enter the value.	50 to 100%	80%
Sleep	Sleep is a function that decreases the brightness of LCD touch panel to save electricity when there is no touch panel operation. Slide the Sleep slide button to the right to turn ON the Sleep function. Then, enter the time period from the last touch panel operation to the time the Sleep state starts.	ON/OFF 1 to 5 min	ON 2 min
Brightness (Sleep)	Brightness of the LCD touch panel in sleep state. You can set the value using the slider bar or tapping the input field to enter the value.	0 to 50%	20%

5. Tap the Apply button.

▶ The values are saved and the screen returns to the Tools screen.

6. Tap the Top button on the Tools screen.

▶ The screen returns to the Top screen.

OTHER SETTINGS

Setting DAQ

The DAQ setting is required when the optional interface board is installed (page 56).
For installing the interface board, contact our sales representative or agent.

1. On the Top Screen, tap the Menu button.
▶ The Menu screen is displayed.

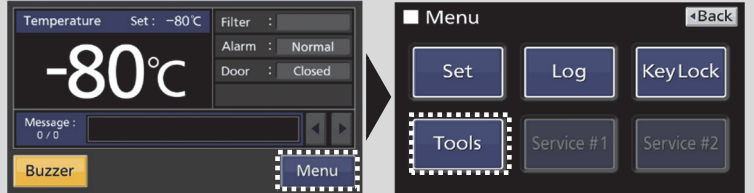

2. Tap the Tools button on the Menu screen.
▶ The Tools screen is displayed.

3. Tap the DAQ Setting button on the Tools screen.
▶ The DAQ Setting screen is displayed.

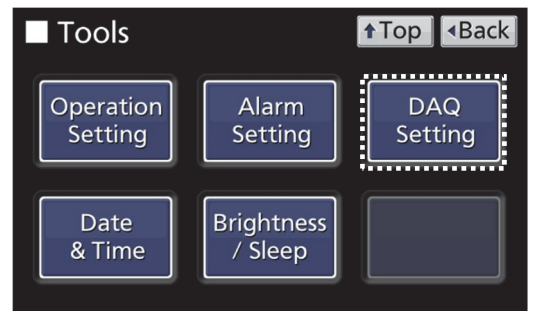

4. Configure each setting on the DAQ Setting screen.

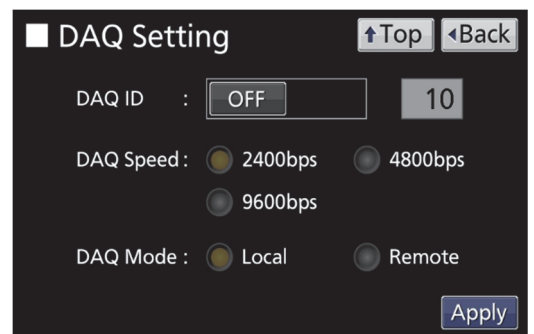

Details of settings:

Item	Details	Settable range	Default value
DAQ ID	Slide the DAQ ID to the right to set it to ON. Then, tap the input field next to the slide button to enter the ID value (1 to 250). Enter the value that is not used for other equipment. Note: Setting for the DAQ Speed and DAQ Mode becomes available when this setting is turned ON.	ON/OFF ID value: 1 to 250	OFF
DAQ Speed	Select the communication speed when the centralized monitoring (DAQ system) is connected by tapping the radio button.	2,400 bps, 4,800 bps, or 9,600 bps	2,400 bps ^{*2}
DAQ Mode	Select Local or Remote by tapping the radio button.	Local/Remote ^{*1}	Local ^{*2}

*1 When "Remote" is selected, you cannot set the chamber temperature set point, high/low alarms, other alarm settings, and compressor delay time from the freezer. The configuration can be set from the remote side.

*2 These are the values when the DAQ ID is turned on for the first time.

5. Tap the Apply button.
▶ The values are saved and the screen returns to the Tools screen.

6. Tap the Top button on the Tools screen.
▶ The screen returns to the Top screen.

OPERATION LOG

The product is equipped with a function to store operation log data (chamber temperature and outer door open/close status).

- Up to about 664-day logs (when the log interval is set to 30 minutes) can be stored. When log data reaches the maximum storage amount, the oldest log data is overwritten with the new data.
- When the battery switch for power failure alarm is turned on and the battery capacity is remaining, the log data continues to be recorded even during a power failure.

Setting log interval and unique ID

The interval to record the operation log data and the unique ID that is used when exporting the operation log data can be set as follows.

1. On the Top Screen, tap the Menu button.
▶ The Menu screen is displayed.

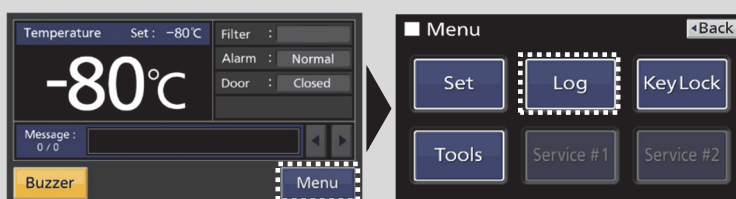

2. Tap the Log button on the Menu screen.
▶ The Log screen is displayed.

3. Tap the Setting button on the Log screen.
▶ The Setting screen is displayed.

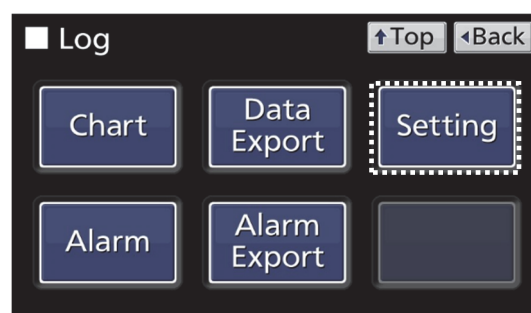

4. Enter each value in the Setting screen by tapping each input field.

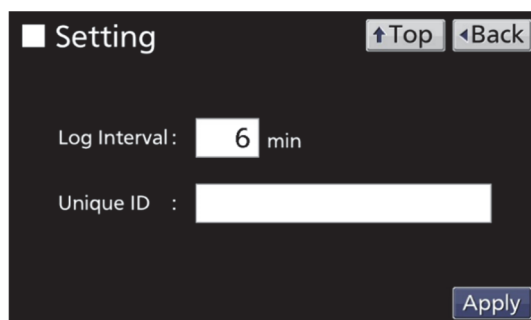

Details of entry:

Item	Details	Settable range	Default value
Log Interval	Enter the interval for storing the operation log data. • Log interval and the estimated amount of data that can be stored: Every 2 minutes: Approx. 46-day data Every 6 minutes: Approx. 135-day data Every 30 minutes: Approx. 664-day data	2 to 30 min (in 2 minute increments)	6 min
Unique ID	The unique ID entered in this field is shown at the beginning of the exported log file (.csv) following the product name. e.g. Product name: MDF-DU700ZHA, Unique ID: ABC00001 →MDF-DU700ZH, ABC00001	8 alphanumeric characters	-

5. Tap the Apply button.
▶ The values are saved and the screen returns to the Log screen.
6. Tap the Top button on the Log screen.
▶ The screen returns to the Top screen.

OPERATION LOG

Displaying operation log chart

Operation log data (chamber temperature and outer door open/close status) stored in the freezer can be displayed in chart format on the LCD touch panel.

1. On the Top Screen, tap the Menu button.
▶ The Menu screen is displayed.

2. Tap the Log button on the Menu screen.
▶ The Log screen is displayed.

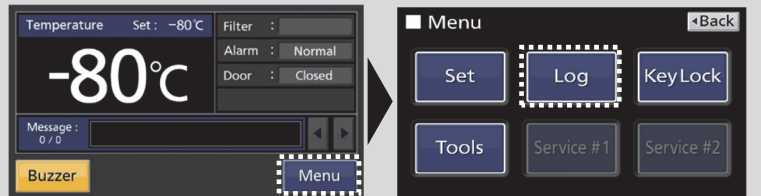

3. Tap the Chart button on the Log screen.
▶ The Chart screen is displayed.

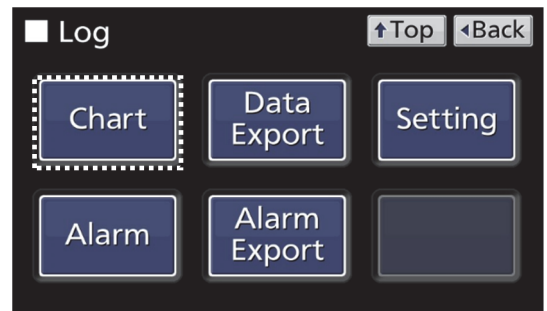

4. Tap each of the Date input fields to enter the date of the operation log you want to display.
▶ The numeric input window is displayed.

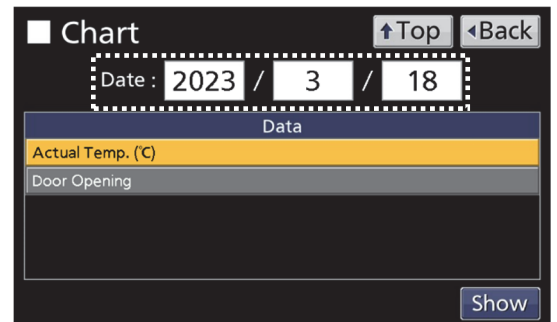

5. Tap the desired operation log type item.
▶ Selected item is highlighted in orange.

Actual Temp.: Chamber temperature log chart
Door Opening: Outer door open/close status log chart

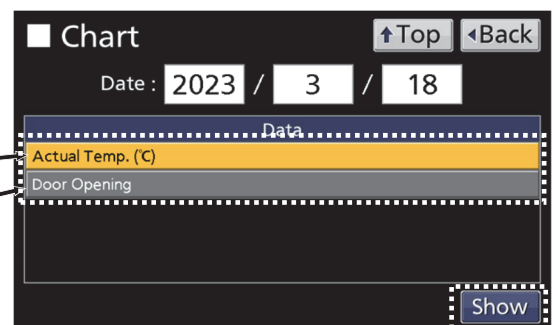

6. Tap the Show button.
▶ Operation log chart on the selected date and type is displayed.

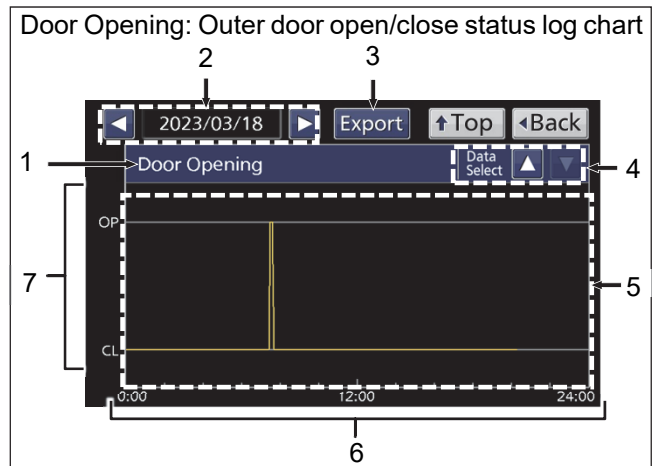
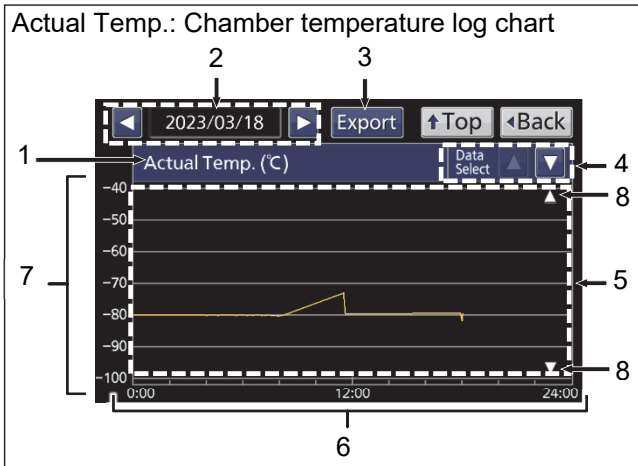

No.	Item	Details
1	Chart title	Title of the selected chart is displayed here. Actual Temp.: Chamber temperature log chart Door Opening: Outer door open/close status log chart
2	Date	Indicates the day when the operation log data was recorded. Tapping the ◀ and ▶ buttons can display the previous date and next date respectively.
3	Export button	Tapping this button exports the data displayed on the chart to the USB flash drive inserted into the USB port in CSV format.
4	Chart selection buttons	Tapping the ▲ button displays the Actual Temp. chart. Tapping the ▼ button displays the Door Opening chart.
5	Chart display area	A chart is displayed within this area.
6	Horizontal axis	Indicates time.
7	Vertical axis	Actual Temp.: Indicates temperature in the chamber. Door Opening: Indicates the outer door status. OP: Opened, CL: Closed.
8	Temperature log chart scroll buttons	Tapping the ▲ and ▼ buttons can scroll up and down the temperature log chart.

7. Tap the Top button on the Chart screen.
▶ The screen returns to the Top screen.

Exporting the operation log data displayed on the screen

The operation log data displayed on the screen in chart format can be exported to a USB flash drive inserted into the USB port in CSV format.

1. Insert a USB flash drive into the USB port.
For supported USB flash drives, refer to "10. USB port" on page 15.
2. Tap the Export button on the screen displaying the operation log data to be exported.
▶ Export of the operation log data starts.

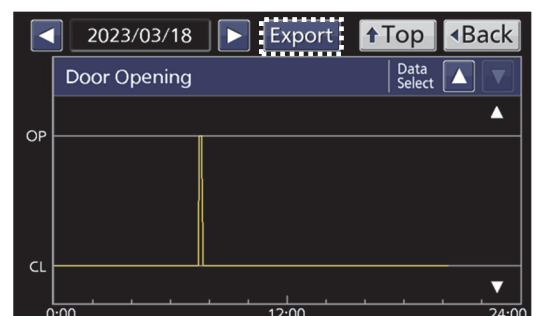

OPERATION LOG

3. Tap the OK button when the Information message notifying the completion of the export is displayed.

▶ The screen returns to the Chart screen.

A folder named “log” is created in the USB flash drive and the exported data file is saved in the folder in CSV format.

The file name consists of the date (YYYY/MM/DD or DD/MM/YYYY) and data name (Temp or Door). The date format specified on the Date & Time screen is used for the date (see page 32).

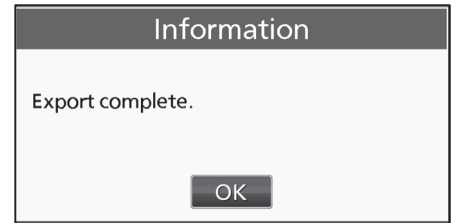

e.g. When the temperature log on March 1 in 2023 is exported.

Year/Month/Day	20230301_Temp.csv
Day/Month/Year	01Mar2023_Temp.csv

e.g. When the outer door status log on March 1 in 2023 is exported.

Year/Month/Day	20230301_Door.csv
Day/Month/Year	01Mar2023_Door.csv

Notes:

- If the file names are duplicated, a sequential number (1 - 99) is added at the end of the file name which is output later.
e.g. 20230301_Temp-1.csv
- The operation log data stored in the freezer is not deleted even if the operation log data is exported to the USB flash drive.
- If an export error occurs, one of the following Notice messages appears.

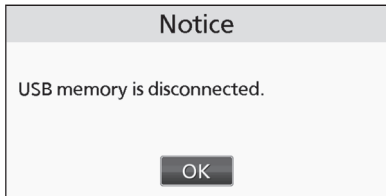
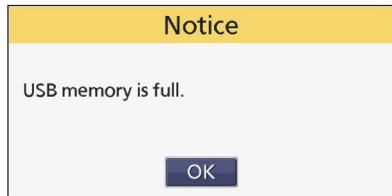
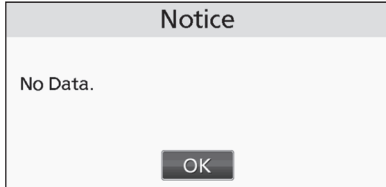
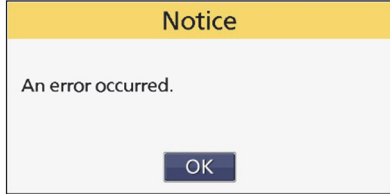
<ul style="list-style-type: none"> • USB flash drive is not inserted into the USB port. • USB flash drive is not inserted properly.  <p>▶ Tap the OK button, and then insert a USB flash drive properly into the USB port.</p>	<ul style="list-style-type: none"> • There is not enough free space in the USB flash drive. • The USB flash drive is not formatted in FAT16 or FAT32 format.  <p>▶ Tap the OK button, and then check the capacity and format type of the USB flash drive.</p>
<ul style="list-style-type: none"> • The log data during the specified period does not exist.  <p>▶ Tap the OK button and specify the data again.</p>	<ul style="list-style-type: none"> • The export was unsuccessful.  <p>▶ Tap the OK button and specify the data again.</p>

4. Remove the USB flash drive from the USB port.

5. Tap the Top button on the screen displaying the chart.

▶ The screen returns to the Top screen.

Exporting operation log data

Operation log data stored in the freezer can be exported to a USB flash drive inserted into the USB port in CSV format. The data can be exported all together or separately by selecting the log type (chamber temperature or outer door open/close status).

1. Insert a USB flash drive into the USB port.

For supported USB flash drives, refer to “10. USB port” on page 15.

2. On the Top Screen, tap the Menu button.

▶ The Menu screen is displayed.

3. Tap the Log button on the Menu screen.

▶ The Log screen is displayed.

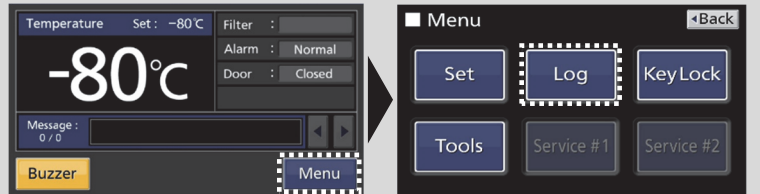

4. Tap the Data Export button on the Log screen.

▶ The Export screen is displayed.

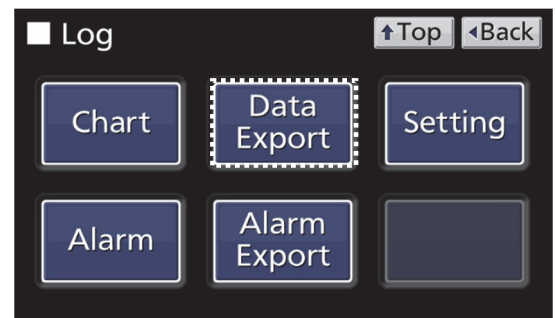

5. Tap the radio button (All or 1 Day) to select the period during which the data was logged.

▶ The selected radio button turns orange.

Item	Details
All	Selects the entire period.
1 DAY	Selects specified 1 day. (Enter the date when the log data you want to export was stored.)

Note: The error of about 1 minute may be observed within a month. Refer to page 32 for setting the time.

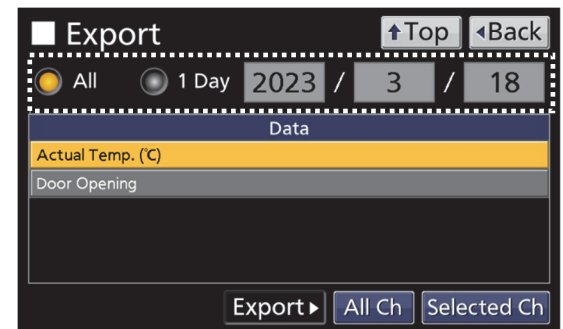

6. Tap the All Ch button, or select a log data type and tap the Selected Ch button to export the log data.

Button	Details
All Ch	Exports all types of the operation log data.
Selected Ch	Exports only one selected operation log data type. Before tapping this button, tap Actual Temp. or Door Opening on the above list to select the log data type (selected data type turns orange).

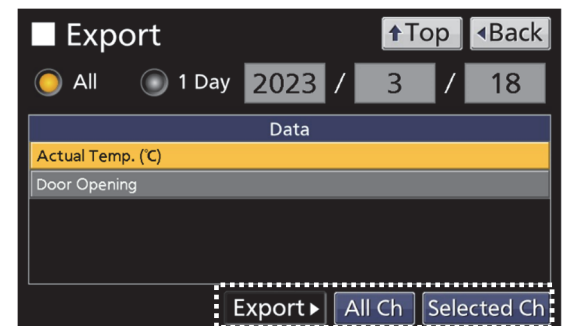

OPERATION LOG

7. Tap the OK button when the Information message notifying the completion of the export is displayed.

▶ The screen returns to the Export screen.

A folder named “log” is created in the USB flash drive and the exported data file is saved in the folder in CSV format.

The file name consists of the specified date period (YYYY/MM/DD-YYYY/MM/DD or DD/MM/YYYY-DD/MM/YYYY) and data name (Temp, Door, or AllCh). The date format specified on the Date & Time screen is used for the date (see page 32).

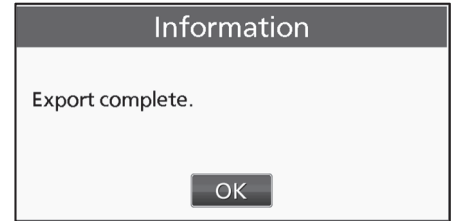

Examples of exported file names when “All” period (in the case of March 1 in 2023 to April 1 in 2023) is selected and the “All Ch” button is tapped to export all types of operation log data.

Year/Month/Day	20230301-20230401_AllCh.csv 20230301-20230401_Door.csv
Day/Month/Year	01Mar2023-01Apr2023_AllCh.csv 01Mar2023-01Apr2023_Door.csv

*When the “All Ch” button is selected to export all types of operation log data, two files (AllCh.csv and Door.csv) are exported.

Examples of exported file names when “1 Day” (in the case of March 1 in 2023) is selected, “Door Opening” log is selected, and the “Selected Ch” button is tapped to export the door open/close status log.

Year/Month/Day	20230301_Door.csv
Day/Month/Year	01Mar2023_Door.csv

Notes:

- If the file names are duplicated, a sequential number (1 - 99) is added at the end of the file name which is output later.
e.g. 20230301_Door-1.csv
- The operation log data stored in the freezer is not deleted even if the operation log data is exported to the USB flash drive.
- If an export error occurs, refer to page 38.

8. Remove the USB flash drive from the USB port.

9. Tap the Top button on the Export screen.

▶ The screen returns to the Top screen.

ALARM LOG

This product is equipped with a function to store alarm log data.

- Up to about 256 logs can be stored. When the number of logs exceeds the maximum number, the oldest log data is overwritten with the new data.
- When the battery switch for power failure alarm is turned on and the battery capacity is remaining, the log data continues to be recorded even during a power failure.

Referring to the alarm logs

Alarm log data stored in the freezer can be displayed for reference by selecting the period during which the alarms occurred.

1. On the Top Screen, tap the Menu button.
▶ The Menu screen is displayed.

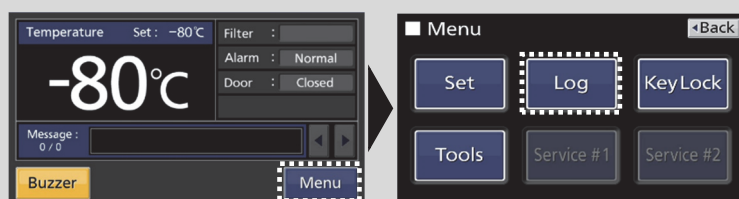

2. Tap the Log button on the Menu screen.
▶ The Log screen is displayed.

3. Tap the Alarm button on the Log screen.
▶ The Alarm screen is displayed.

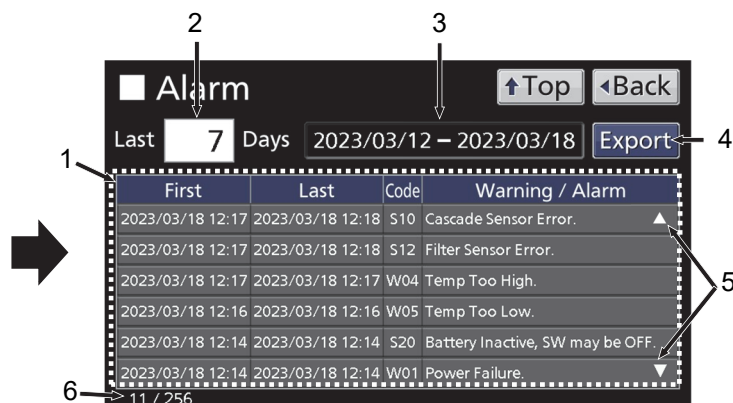
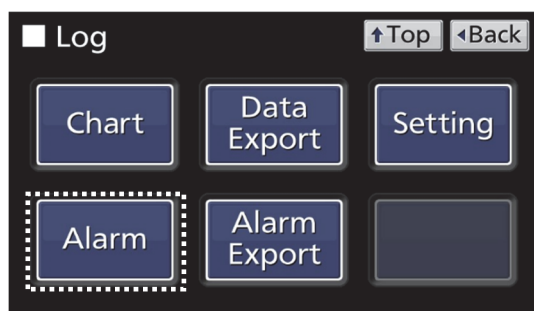

Details of the Alarm screen

No.	Item	Details
1	Alarm log information	Indicates alarm log information stored in the freezer First: Date and time when the alarm condition occurred. Last: Date and time when the alarm condition ended. *The date format specified on the Date & Time screen is used for the date indication (see page 32). Code: Error code. Warning/Alarm: Details of the warning/alarm.
2	Number of days	Tap the input field to enter the period of days you want to display the alarm log that occurred on and before the current date. Settable range: 1 to 45 days
3	Period indication	Period corresponding to the days input in the number of days (No.2) field is displayed here. *The date format specified on the Date & Time screen is used for the date indication (see page 32).
4	Export button	Tapping this button exports the alarm log data during specified period to the USB flash drive inserted into the USB port in CSV format.
5	Scroll buttons	When logs during the specified period are more than 7, tapping the scroll button shows the upper or lower log. Tapping the ▲ button scrolls up one line. Tapping the ▼ button scrolls down one line.
6	Number of logs	Number of logs during the specified period / Total alarm logs.

ALARM LOG

- 4. Tap the Number of days input field.
▶ Numeric input window for entering number is displayed.

- 5. Enter desired number of days and tap the OK button.
▶ Alarm log data during the specified period is displayed.

Note:

When logs during the specified period are more than 6, tapping the scroll button shows the upper or lower log.

- 6. After referring to the alarm logs, tap the Top button.
▶ The screen returns to the Top screen.

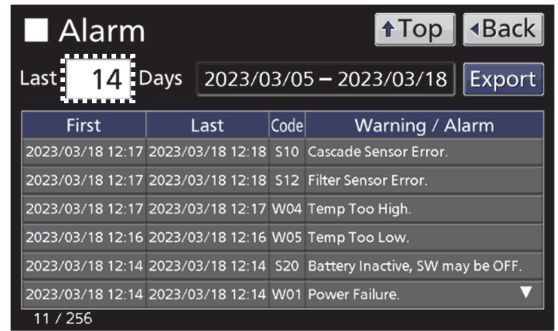

Exporting alarm log data when referring to the data

The alarm log data displayed on the Alarm screen for reference can be exported to a USB flash drive inserted into the USB port in CSV format.

- 1. Insert a USB flash drive into the USB port.
For supported USB flash drives, refer to “10. USB port” on page 15.

- 2. Tap the Export button on the Alarm screen.
▶ Export of the alarm log data during the specified days starts.

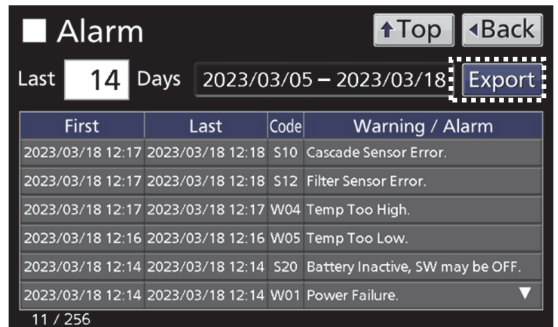

- 3. Tap the OK button when the Information message notifying the completion of the export is displayed.
▶ The screen returns to the Alarm screen.
A folder named “log” is created in the USB flash drive and the exported data file is saved in the folder in CSV format. The file name consists of the specified date period (YYYY/MM/DD-YYYY/MM/DD or DD/MM/YYYY-DD/MM/YYYY) and data name (AlarmLog). The date format specified on the Date & Time screen is used for the date (see page 32).

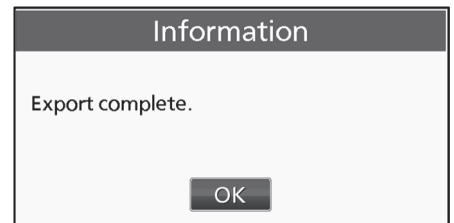

Examples of exported file names when “14” is input in the number of days field on March 18 in 2023 (in this case, the days correspond to the period from March 5 in 2023 to March 18 in 2023).

Year/Month/Day	20230305-20230318_AlarmLog.csv
Day/Month/Year	05Mar2023-18Mar2023_AlarmLog.csv

Notes:

- If the file names are duplicated, a sequential number (1 - 99) is added at the end of the file name which is output later.
e.g. 20230305-20230318_AlarmLog-1.csv
- The alarm log data stored in the freezer is not deleted even if the alarm log data is exported to the USB flash drive.
- If an export error occurs, refer to page 38.

4. Remove the USB flash drive from the USB port.

5. Tap the Top button on the Alarm screen.

- ▶ The screen returns to the Top screen.

ALARM LOG

Exporting alarm log data

Alarm log data stored in the freezer can be exported to a USB flash drive inserted into the USB port in CSV format.

1. Insert a USB flash drive into the USB port.
For supported USB flash drives, refer to “10. USB port” on page 15.

2. On the Top Screen, tap the Menu button.
▶ The Menu screen is displayed.

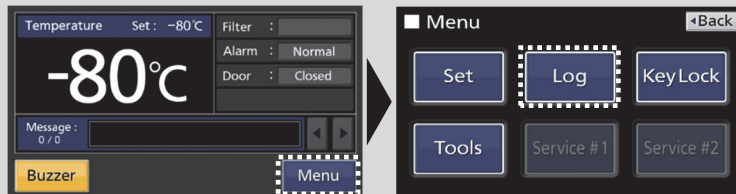

3. Tap the Log button on the Menu screen.
▶ The Log screen is displayed.

4. Tap the Alarm Export button on the Log screen.
▶ The Alarm Export screen is displayed.

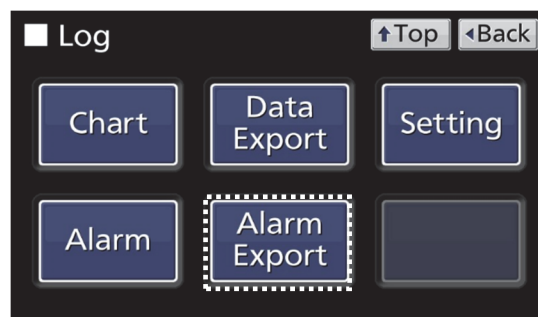

5. Tap the “All” or “Last Days” radio button to select the period during which the data was logged.
▶ The selected radio button turns orange.

Item	Details
All	Selects the entire period.
Last <input type="checkbox"/> Days	Tap the input field to enter the period of days you want to export the alarm log that occurred on and before the current date. Settable range: 1 to 45 days

Note: The error of about 1 minute may be observed within a month. Refer to page 32 for setting the time.



6. Tap the Export button.
▶ Export of the log data in the selected period starts.

7. Tap the OK button when the Information message notifying the completion of the export is displayed.

▶ The screen returns to the Alarm Export screen.

A folder named “log” is created in the USB flash drive and the exported data file is saved in the folder in CSV format.

The file name consists of the specified date period (YYYY/MM/DD-YYYY/MM/DD or DD/MM/YYYY-DD/MM/YYYY) and data name (AlarmLog). The date format specified on the Date & Time screen is used for the date (see page 32).

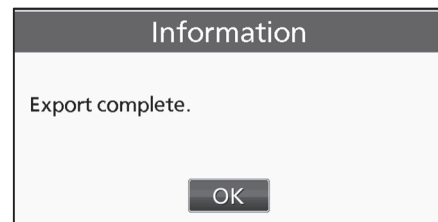

Examples of exported file names when “All” period (in the case of March 1 in 2023 to April 1 in 2023) is selected to export the alarm log data.

Year/Month/Day	20230301-20230401_AlarmLog.csv
Day/Month/Year	01Mar2023-01Apr2023_AlarmLog.csv

Examples of exported file names when “Last Days” is selected to export the alarm log data (in this case, “7” is entered in the field and the days correspond to the period from March 12 in 2023 to March 18 in 2023).

Year/Month/Day	20230312-20230318_AlarmLog.csv
Day/Month/Year	12Mar2023-18Mar2023_AlarmLog.csv

Notes:

- If the file names are duplicated, a sequential number (1 - 99) is added at the end of the file name which is output later.
e.g. 20230301-20230401_AlarmLog-1.csv
- The alarm log data stored in the freezer is not deleted even if the alarm log data is exported to the USB flash drive.
- If an export error occurs, refer to page 38.

8. Remove the USB flash drive from the USB port.

9. Tap the Top button on the Alarm Export screen.

▶ The screen returns to the Top screen.

4. MAINTENANCE & TROUBLESHOOTING

ALARMS AND SELF-DIAGNOSIS

Warning messages



The cooling performance has been significantly degraded. Thus, the chamber temperature may get considerably higher. Take some measures to protect the stored samples immediately (e.g. transferring the stored samples to another freezer) except when the cause is apparent and the chamber temperature can recover soon. Turn off the power switch and contact our sales representative or agent.

LCD touch panel Message display area	Warning type, Situation	Audible alarm	Temp. Indication	Remote Alarm	
Warning: Temp Control Failure. W01: Power Failure.	[Power failure alarm] The battery switch for power failure alarm is ON, and under any of the following conditions: •During a power failure •Power switch is OFF •Power supply cord is disconnected.	Intermittent tone	Normal indication	ON	
Warning: Temp Control Failure. *1 W02: Compressor Temp Abnormal.	[Compressor temp. abnormal] When the fan motor for cooling the compressor fails or when the ambient temperature is out of the usable environment condition.				
Warning: Temp Too High. W04	[High temp. alarm] (after set alarm delay time has elapsed) The chamber temperature has exceeded the temp. set point + the value set for High Alarm.				
Warning: Temp Too Low. W05	[Low temp. alarm] (after set alarm delay time has elapsed) The chamber temperature has fallen below the temp. set point - the value set for Low Alarm.		Blinking		
Warning: Temp Control Failure. W06: Compressor 'H' Control Failure.	[Internal communication error] Compressor control failure due to communication failure with H side inverter.		Normal indication		
Warning: Temp Control Failure. W07: Compressor 'L' Control Failure.	[Internal communication error] Compressor control failure due to communication failure with L side inverter.		Normal indication		
Warning: Temp Control Failure. *2 W08: Temperature Controller Failure.	[Internal communication error] Communication between LCD touch panel and control circuit board is unstable.		OFF		—
Warning: Temp Control Failure. *3 W09: Temperature Sensor Error.	[Temperature sensor disconnected] The thermal sensor has been disconnected.		Blinking		ON
Warning: Temp Control Failure. *3 W10: Temperature Sensor Error.	[Temperature sensor short-circuited] The thermal sensor has been short-circuited.				
Warning: Temp Control Failure. W15: Cascade Temp Abnormal.	[Cascade temp. abnormal] The cascade temperature has risen during the activation of high temp. alarm.				
Door: Door Open	[Door alarm] Outer door is open.	Intermittent tone *4	indication	—	

*1: The compressor stops in the case of W02.

*2: In the case of W08, chamber temperature is not displayed. Moreover, the LCD touch panel cannot be operated.

*3: The compressor runs continuously in the case of W09 or W10.

If the *1 and *3 situations (W02 and W09/W10) occur at the same time, stopping of the compressor has a higher priority over running continuously.

*4: Activates after set door delay time has elapsed.

Alarm messages



Cooling performance may degrade and the chamber temperature may rise. When the temperature change is temporary due to user operation, wait for the recovery of chamber temperature. In other cases, if this status continues, failure or chamber temperature rise may occur. Take some measures to protect the stored samples. In such a case, contact our sales representative or agent.

LCD touch panel Message display field	Alarm type, Situation	Audible alarm	Temp. Indication	Remote alarm
Alarm: Temp Too High. A04	[High temp. alarm] (during set alarm delay time) The chamber temperature has exceeded the temp. setpoint + the set value of High Alarm.	—	Blinking	—
Alarm: Temp Too Low. A05	[Low temp. alarm] (during set alarm delay time) The chamber temperature has fallen below the temp. setpoint. - the set value of Low Alarm.			

Status messages



There is a possibility of failure other than the cooling performance. The chamber temperature is controlled. If this status continues, the alarm may not activate in the case of any failure. Contact our sales representative or agent.

LCD touch panel Message display area	Status, Situation	Audible alarm	Temp. Indication	Remote Alarm
Status: Temp Control Risk. S01: Cooling Circuits Overload. *5	[Overload operation] The chamber temp. has not reached the temp. set point for approx. 5 days or more.	—	Normal indication	—
Status: Temp Under Control. S02: Ambient Temp Abnormal. *6	[Abnormal ambient temperature] The ambient temp. is over 35°C or lower than 0°C.			
Status: Temp Under Control. S10: Cascade Sensor Error.	[Cascade sensor disconnected] The cascade sensor has been disconnected.			
Status: Temp Under Control. S11: Cascade Sensor Error.	[Cascade sensor short-circuited] The cascade sensor has been short-circuited.			
Status: Temp Under Control. S12: Filter Sensor Error.	[Filter sensor disconnected] The filter sensor has been disconnected.			
Status: Temp Under Control. S13: Filter Sensor Error.	[Filter sensor short-circuited] Filter Sensor has been short-circuited.			
Status: Temp Under Control. S14: Ambient Temp Sensor Error.	[Ambient temp. sensor disconnected] The ambient temp. sensor has been disconnected.			
Status: Temp Under Control. S15: Ambient Temp Sensor Error.	[Ambient temp. sensor short-circuited] The ambient temp. sensor has been short-circuited.			
Status: Temp Under Control. S16: Main Battery Charging Failure.	[Battery for power failure alarm charging failure] The battery voltage does not increase after a certain period of time.			
Status: Temp Under Control. S17: Backup Battery Charging Failure.	[Battery for backup cooling system charging failure] The battery voltage does not increase after a certain period of time.			
Status: Temp Under Control. S18: Exchange a Main Battery.	[Battery for power failure alarm replacement] About 3-year total operation time has passed.			
Status: Temp Under Control. S19: Exchange a Backup Battery.	[Battery for backup cooling system replacement] The backup cooling system has been ON for over 3 years in total.			
Status: Temp Under Control. S20: Battery Inactive. SW may be OFF.	[Check for battery switch for power failure alarm] The battery switch for power failure alarm is OFF.			

*5: In the case of S01, check the following:

- (1) There are too many samples stored in the chamber at a time.
- (2) The door is frequently opened or the door gasket is damaged.
- (3) The chamber temperature should be set to -80°C or higher.

*6: In the case of S02, check the air conditioning at the installation site. The ambient temperature should be 5°C to 30°C.

ALARMS AND SELF-DIAGNOSIS

Alarm and Buzzer button

1. The behaviors of the alarm indication and the ring back function when tapping the Buzzer button are as follows.

● **In the cases other than the door alarm and communication error**

<Setting of the freezer>

Remote alarm setting	Ring back setting
ON: Not linked with Buzzer button	ON
	OFF
OFF: Linked with Buzzer button	ON
	OFF

<Alarm behavior>

Alarm sound from freezer		Remote Alarm	
When Buzzer button is tapped	After the set ring back time has elapsed	When Buzzer button is tapped	After the set ring back time has elapsed
OFF (Alarm is not canceled)	ON	ON	ON (Alarm status is continuing)
	OFF		ON
	ON	OFF (Alarm is not canceled)	ON
	OFF		OFF

Note:

Tapping the Buzzer button when the audible alarm is beeping stops the sound. However, the cause of the alarm is not solved by only tapping this button. Refer to pages 46 and 47 to know the cause of the alarm and solve the problem.

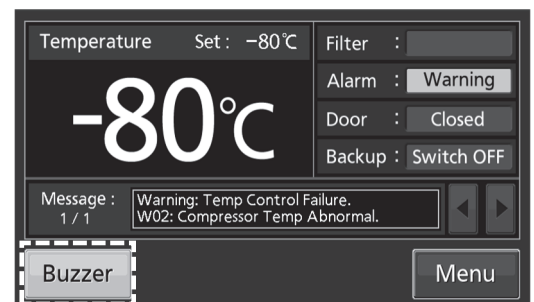

● **In the cases of the door alarm**

<Setting of the freezer>

Remote Alarm setting	Ring Back setting
ON: Not linked with Buzzer button	ON
	OFF
OFF: Linked with Buzzer button	ON
	OFF

<Alarm behavior>

Alarm sound from freezer		Remote Alarm (Door alarm does not link with remote alarm)
When Buzzer button is tapped	After the set ring back time has elapsed	
OFF (Alarm is canceled)	OFF (Alarm is already canceled)	—

2. The alarm indication after the freezer gets out of a high/low alarm condition without user intervention or after recovery from a power failure is as follows.

Resolved alarm	LCD touch panel		Audible alarm	Remote alarm
	Message display area	Alarm indicator		
High alarm Low alarm Power failure alarm	—	“Alarm” is displayed alternately in normal and reverse video.	Intermittent tone	—

Note:

Tapping the Buzzer button stops the alarm sound and changes the alarm indicator to “Normal”.

ROUTINE MAINTENANCE

Cleaning the exterior, interior, and accessories

- Clean the unit once a month. Regular cleaning keeps the unit in good condition.
- Use a dry cloth to wipe down the outside and inside of the unit and all accessories. If the outside panels are dirty, clean them with a diluted neutral dish-washing detergent (using an undiluted solution of detergent may cause the unit's plastic areas to crack. Follow the directions on the detergent for details of dilution). After wiping the unit or accessories with a diluted detergent, be absolutely sure to wipe the surfaces using a cloth moistened with clean water to remove traces of the detergent. After this, be absolutely sure to wipe the surfaces with a dry cloth.
- Do not use a brush, acid, thinner, laundry soap, powder detergent, or boiling water for cleaning. These may cause damage to painted surfaces or cause perishing of plastic and rubber components. Moreover, do not wipe plastic and rubber components with a volatile material.
- When wiping the control panel with a damp cloth, wipe out the surface so that the droplets do not remain on the surface.
- Do not clean the entire freezer unit using peracetic acid or hydrogen peroxide, or do not disinfect the unit by formalin fumigation.
- Never pour water onto or into the unit. Doing so can damage the electric insulation and cause failure.
- The compressor and other mechanical parts are completely sealed. This unit requires absolutely no lubrication.
- Clean the inside of the inner door to remove the frost and ice at least once a month.
- In order to maintain the unit's intended level of performance, always put back accessories that have been removed for cleaning.

Cleaning the condenser filter

This unit is provided with the filter alarm indicator on the LCD touch panel. Clean the condenser filter when this indicator turns on (orange). Clean the condenser filter once a month even if the filter alarm indicator is not on. A dusty condenser filter may cause shorter compressor life as well as the poor cooling.

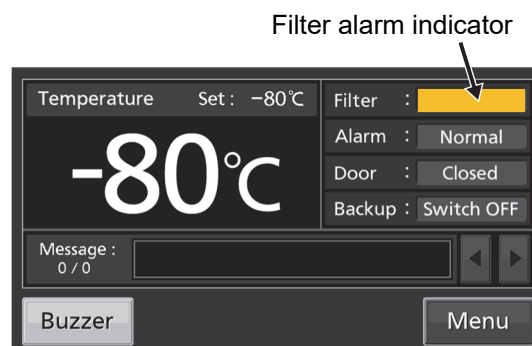

Clean the condenser filter by following the procedure below.

1. Open the grille by pulling it to you as shown in the figure.
2. Take out the condenser filter.
3. Wash the condenser filter with water.
4. Put the condenser filter back (set the filter so that the handle of the filter faces to the front) and close the grille.
5. Check that the filter alarm indicator is turned off if the filter alarm indicator was ON.

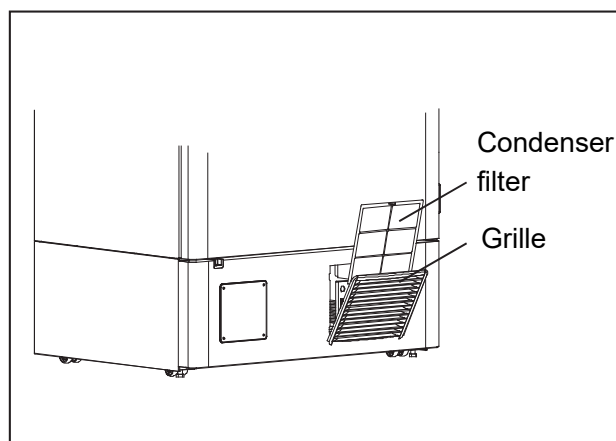

ROUTINE MAINTENANCE

Defrosting the chamber

<p>⚠ WARNING</p>	<ul style="list-style-type: none"> ● Never damage the chamber wall when removing frost. It may cause explosions and/or a fire in case of refrigerant leakage.
<p>⚠ CAUTION</p>	<ul style="list-style-type: none"> ● Wear protective gloves when handling frozen items or cleaning the chamber. Without gloves, you may get frostbite or get injured by the corners of interior parts. Also, touching or inhaling chemicals or aerosols from around the unit may be detrimental to health.

Frost may accumulate on the surface of the door gasket and chamber side surface of the inner door. Excessive accumulation of frost is likely to create gaps between the door and the door gasket, which can degrade the cooling performance. Remove the frost using the scraper that comes with the unit before the accumulation becomes too thick. Follow the steps below to defrost when excessive frost builds up in the chamber.





1. Turn off the switch for the backup cooling system (if installed).
2. Turn off the battery switch for power failure alarm.
3. Take out all contents from the freezer and transfer them to another freezer or a container which is refrigerated by liquid carbon dioxide or dry ice.
4. Turn off the power switch for the freezer unit.
5. Open the outer door and inner door.
6. Leave the freezer in this state until the frost in the chamber melts.
7. Wipe up the water accumulated at the bottom of the chamber with a dry cloth.
8. After cleaning the chamber, start up the unit by following “START-UP PROCEDURE” on page 18.
9. Check that the chamber temperature reaches the set temperature and then put back the contents.

Note:

Do not use a tool with a sharp edge (such as a knife or screw-driver) to remove the frost.

Cleaning the air intake port

When frost and ice is formed in/around the air intake port, clean it as shown below.

Condition	Solution
<p>Frost and ice is formed in the air intake port.</p>	<p>Remove the frost by poking the stick for air intake port cleaning (accessory) into the air intake port.</p> 
<p>The inner door cannot be opened even if the cap on the air intake port is removed.</p>	
<p>Frost and ice is formed in the chamber.</p>	<p>Remove the frost and ice inside the chamber using the scraper (accessory).</p> 

Note:

Do not use a tool with a sharp edge (such as a knife or screw-driver) to remove the frost.

REPLACEMENT OF CONSUMABLE PARTS

! WARNING

- The replacement of the battery for power failure alarm and battery for backup cooling system should be performed by a qualified engineer or service personnel only.
The replacement of the battery involves the risk of electric shock.

«Important»

The used battery is a recyclable resource. Do not dispose of the battery. Always follow the procedure for recycling.

Replacing the battery for power failure alarm

Replace the battery for power failure alarm about every 3 years. Contact our sales representative or agent for the replacement of battery when “S18: Exchange a Main Battery.” is displayed in the message display area.

- The replacement of the battery for power failure alarm is a paid service.
- The power failure alarm (indication on the LCD display, alarm sound, and remote alarm) will not work when the battery for power failure alarm is flat.
- Recording of the operation logs and alarm logs stops when the battery for power failure alarm is flat.
- In the event of a power failure, the battery for power failure alarm is used for displaying the warning “W01: Power Failure” and activates alarm sounds.

Replacing the battery for backup cooling system (option)

Replace the battery for backup cooling system about every 3 years. Contact our sales representative or agent for the replacement of the battery when “S19: Exchange a Backup Battery.” is displayed in the message display area.

- The replacement of the battery for backup cooling system is a paid service.
- The backup cooling system will not function in the event of a power failure when the battery for backup cooling system is flat.
- When the chamber temperature rises, the backup cooling system is activated by the battery for backup cooling system even during a power failure. The regular replacement of the battery for backup cooling system is important to prevent the rise of chamber temperature in the event of an unexpected situation.

CALIBRATION

During continuous operation, the following service tasks must be performed:

- Temperature calibration at least once a year.

For temperature calibration, contact our sales representative or agent.

TROUBLESHOOTING

If the freezer does not seem to be working properly, check the following solutions before making a service call.

<Attention>

If the problem is not resolved by checking the following causes/solutions or if the problem is not shown in the table below, contact our sales representative or agent. If the chamber temperature rose due to the freezer failure, move the samples following the tips on page 11.

Problem	Cause/Solution
Nothing starts up even after the power is turned on.	<ul style="list-style-type: none"> ■ The unit is not connected to the power supply properly. ■ The capacity and voltage of the power supply is not sufficient. ■ There is a power failure. ■ The circuit breaker has tripped. ■ The fuse has blown.
The compressor does not start up when turning ON the power switch (LCD touch panel is turned ON).	<ul style="list-style-type: none"> ■ The capacity of power supply is not sufficient. When the capacity of power supply is not sufficient to start the compressor, the compressor may not start.
The alarm is activated during operation.	<ul style="list-style-type: none"> ■ A user has made a significant change to the chamber temperature set point. ■ The door has been kept open for a long time. ■ Samples with a high temperature have been put in the chamber. <p>* In the above cases, the alarm is spontaneously canceled after a while.</p>
	<ul style="list-style-type: none"> ■ The unit is not connected to the power supply properly. ■ The capacity and voltage of the power supply is not sufficient. ■ There is a power failure. ■ The circuit breaker has tripped. ■ The fuse has blown.
	<ul style="list-style-type: none"> ■ If the LCD touch panel is inoperative, turn the power off and then turn it on again.
Cannot set chamber temperature set point.	<ul style="list-style-type: none"> ■ The key lock function has been set to ON. → Set the key lock function to OFF (pages 30-31). ■ “DAQ Mode” on the DAQ screen is set to “Remote.” → Set the “DAQ Mode” to “Local” (page 34).
During the setting operation, the screen returns to the Top screen.	<ul style="list-style-type: none"> ■ The display will automatically return from each screen to the Top screen when there is no touch panel operation for about 90 seconds (auto return function).
Excessive noise	<ul style="list-style-type: none"> ■ The floor is not stable. ■ The installation site is not level. ■ The freezer is tilted. ■ The freezer is touching the surrounding wall.

Problem	Cause/Solution
The chamber does not cool down enough.	<ul style="list-style-type: none"> ■ A large amount of warm materials has been put in the chamber. ■ There is a large amount of frost built up on the door gasket or inner side of the inner door. ■ The door is frequently opened. ■ The chamber temperature has been set to lower than -86°C. Although the temperature settable range is between -90°C to -40°C, the temperature control range that ensures the cooling performance of this freezer is between -86°C to -40°C. ■ The ambient temperature is over 30°C. The ambient temperature that ensures the cooling performance of this freezer is between 5°C to 30°C. ■ The unit is in direct sunlight. ■ The freezer unit is not installed in the appropriate place described in this operating instructions. ■ The ventilation around the unit is blocked. ■ The grille (air intake vent) is blocked. ■ The condenser filter is clogged. ■ There is a nearby heat source. ■ The access port is not covered. → The access port should be covered with insulation and rubber caps when not in use. ■ The door gasket is damaged. → If it is damaged, contact our sales representative or agent for replacement. ■ A foreign substance has got into the door gasket.
The exterior of the freezer is wet with water droplets.	<ul style="list-style-type: none"> ■ When hot humid weather continues or depending on the installation site, the exterior of the freezer may be wet with water droplets. However, this is not a malfunction. When water vapor in the air is cooled down by the cold exterior of the freezer, the vapor condenses into small droplets. Wipe the droplets with a dry cloth.
The motor sound or flowing liquid sound is noisy.	<ul style="list-style-type: none"> ■ Due to the characteristics of the cooling circuit, the sound of the motor or the flowing refrigerant may be heard during operation. Especially a few hours after starting the operation, the sound of the compressor or the flowing refrigerant may be loud, but it is a normal operation.
Cannot export data to the USB flash drive.	<ul style="list-style-type: none"> ■ The USB flash drive is not inserted properly. ■ Data during the specified time period does not exist. ■ The USB flash drive is full. ■ The USB flash drive has not been formatted in FAT16 or FAT32 format. ■ The USB flash drive that requires password is used. ■ The USB flash drive with capacity of more than 32 GB is used.

DISPOSAL OF UNIT

Before disposing of the freezer unit with biohazardous danger, decontaminate the unit to the extent possible by the user.

 WARNING	<ul style="list-style-type: none">● If the unit is to be stored unused in an unsupervised area for a long period, ensure that children do not have access to the unit and that doors cannot be closed completely. There may be a risk of child entrapment.
	<ul style="list-style-type: none">● Do not give strong shock or vibration when moving or using the unit. The piping may be damaged, causing a fire.
	<ul style="list-style-type: none">● Flammable and explosive product. The unit contains flammable refrigerant. When repairing or recycling the unit, only trained service personnel should perform the work. Follow the procedure below.<ul style="list-style-type: none">■ Well ventilate the room to prevent refrigerant accumulation.■ Keep fire away when the refrigerant is contained in the product.■ Do not damage or break the pipework.
	<ul style="list-style-type: none">● There is a risk of fire or explosion. Dispose of properly in accordance with federal or local regulations. Flammable refrigerant used.

Recycle of battery

(Only for USA and CANADA)

A sealed lead acid battery that is recyclable powers the product you have purchased. At the end of its useful life, under various state and local laws, it is illegal to dispose of this battery into your municipal waste stream.

L'appareil que vous êtes procuré est alimenté par une batterie au plomb étanche. Après la fin de la vie utile de la batterie, en vertu de diverses réglementations gouvernementales et locales, il est illégal de l'éliminer avec les déchets domestiques ordinaires.



Pb

- USE THE SPECIFIED CHARGER.



- This label is a recycle mark complying with the Taiwanese battery regulation.

(Apenas para a Brasil)



CHUMBO

Baterias de chumbo – ácido:

Atenção sobre a bateria:

- Após o uso, a bateria deverá ser devolvida à rede de assistência técnica ou revendedores para ser encaminhada ao fabricante ou importador. (Resolução CONAMA ns° 401)
- **Riscos a saúde:** O contato com os componentes químicos internos desta bateria pode causar danos a saúde.
- **Riscos ao meio-ambiente:** A destinação final inadequada pode poluir águas e solo.
- **Composição básica:** Chumbo, ácido sulfúrico diluído e plástico.

5. OPTIONS & SPECIFICATIONS etc.

OPTIONAL COMPONENTS

Temperature recorder (MTR-85H, MTR-G85A)

The chamber temperature can be recorded and checked by installing the optional temperature recorder MTR-85H or MTR-G85A.

Contact our sales representative or agent for the purchase of the temperature recorder.

Main specifications of temperature recorder

	MTR-85H	MTR-G85A
Temperature recording range	-100°C to +50°C	-100°C to +40°C
Feed speed of recording paper	2-month/batch	1-day/1 turn, 7-day/1 turn, 32-day/1 turn (can be switched)
Recording paper	Strip type	Circular type
Power source	Dry cell	Supplied from the unit

Optional parts required for installing temperature recorders

	MTR-85H	MTR-G85A
Recorder fixing	MDF-S3085	-
Recorder sensor cover	MTR-DU700SF	

Backup cooling kit (MDF-UB7)

When the unit stops operation in the event of a power failure, the optional backup cooling kit MDF-UB7 and the liquid CO₂ cylinder can prevent the chamber temperature from rising for several hours by injecting liquid CO₂ into the chamber.

- Contact our sales representative or agent for the purchase and installation of the backup cooling kit.

! WARNING

- **Install the unit in a well-ventilated (airy) location**

As with any equipment that uses CO₂ gas, there is a likelihood of oxygen depletion in the vicinity of the equipment. It is important that you assess the work site to ensure there is suitable and sufficient ventilation. If restricted ventilation is suspected, then other methods of ensuring a safe environment must be considered. These may include atmosphere monitoring systems and warning devices with alarm functions.

The injection start temperature of the backup cooling system can be set using the temperature setting knob (page 15). However, the actual injection start temperature slightly deviates from the set injection start temperature.

Activation of the backup cooling system

- Settable range of the injection start temperature: -70°C to -50°C

For example, when the injection start temperature of the backup cooling system is set to -70°C, the injection starts at a temperature of -67°C to -65°C and stops at a temperature of -75°C to -74°C.

Backup power switch (Page 15)	Backup indicator (Page 22)	Condition of the backup cooling system	Chamber temperature	Liquid CO ₂
ON	Switch ON	Ready to inject	Lower than the injection start temperature.	No injection
			Equal to or higher than the injection start temperature.	Injection starts
OFF	Switch OFF	Not ready to inject (Backup test switch does not work)	Lower than the injection start temperature	No injection
			Equal to or higher than the injection start temperature.	

Note:

Set the injection start temperature of the backup cooling system to at least 10°C higher than the freezer chamber temperature set point. Otherwise, the liquid CO₂ may be injected continuously into the chamber, consuming the liquid CO₂ in the cylinder wastefully.

SETTING OF SHELF STOPPERS WHEN USING INVENTORY RACKS

Optional inventory racks (IR-220U/ IR-224U) are available for effectively storing frozen samples in the chamber. For using the inventory racks, make sure to set the shelf stoppers at the positions shown in the following figure. When inserting the inventory rack into the chamber, be careful not to bump the rack against the door gasket and the chamber walls. If they are damaged, the cooling performance of the freezer may deteriorate.

 CAUTION	<ul style="list-style-type: none"> ● Set up or remove the shelf with both hands. If the shelf falls down, it may cause injury.
	<ul style="list-style-type: none"> ● When using the inventory racks, be careful not to drop the racks. If the rack falls down, it may cause injury or damage to the contents.

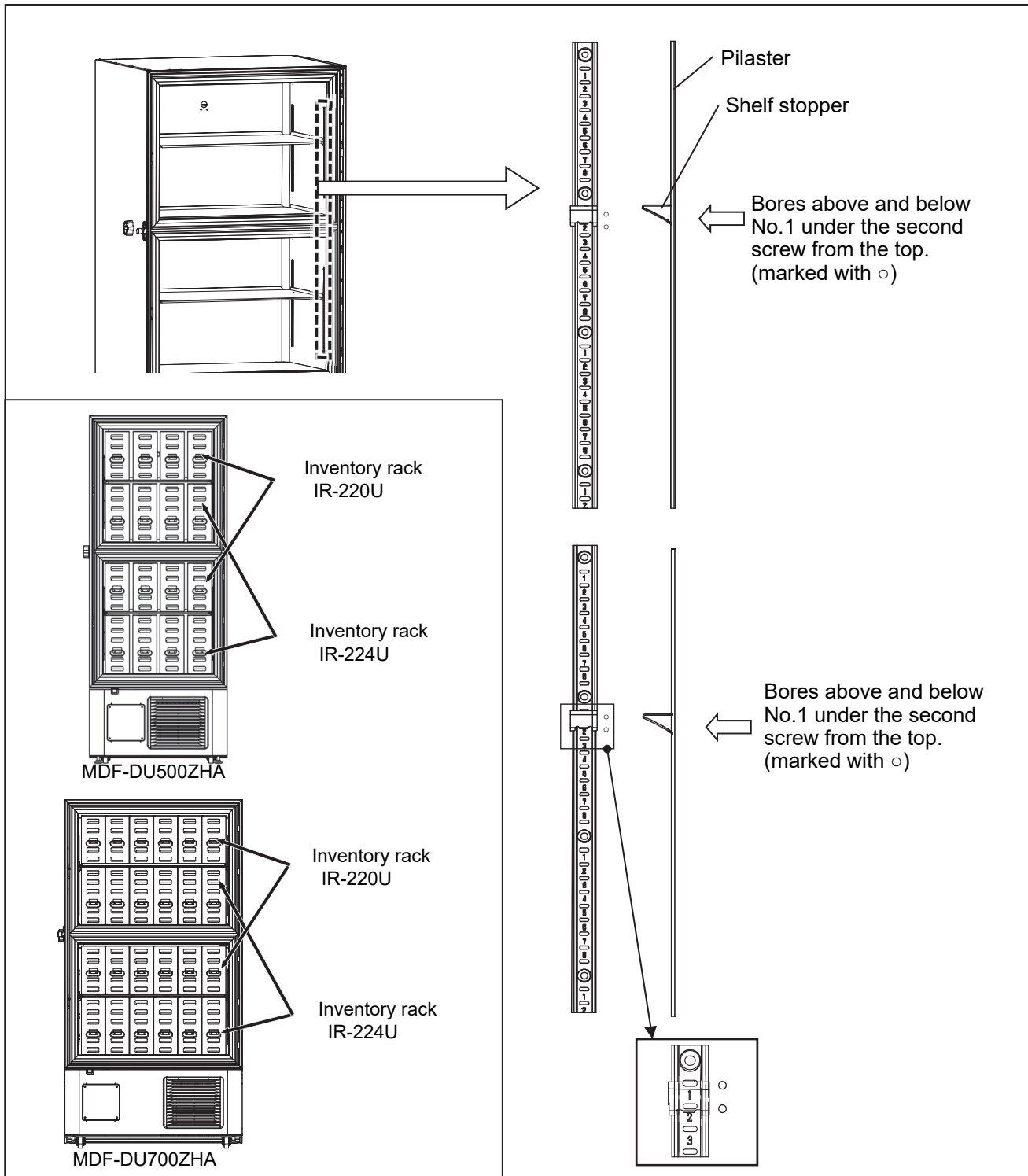

SPECIFICATIONS

Product name		Ultra-Low Temperature Freezer MDF-DU500ZHA	Ultra-Low Temperature Freezer MDF-DU700ZHA	
External dimensions	Width	790 mm (31.1 in.)	1,030 mm (40.6 in.)	
	Depth	882 mm (34.7 in.)	882 mm (34.7 in.)	
	Height	1,993 mm (78.5 in.)	1,993 mm (78.5 in.)	
Internal dimensions	Width	630 mm (24.8 in.)	870 mm (34.3 in.)	
	Depth	607 mm (23.9 in.)	607 mm (23.9 in.)	
	Height	1,400 mm (55.1 in.)	1,400 mm (55.1 in.)	
Effective capacity		525 L (18.5 cu.ft.)	725 L (25.6 cu.ft.)	
Exterior		Painted steel		
Interior		Painted steel		
Outer door		Painted steel, Rigid polyurethane foam		
Inner door		Rigid polyurethane foam + Vacuum insulation panel		
Shelf	Stainless steel, 2 shelves (adjustable) Inner dimension: W615 mm (24.2 in.) x D534 mm (21.0 in.) Load: Max. 50 kg (110 lbs) /shelf		Stainless steel, 2 shelves (adjustable) Inner dimension: W855 mm (33.7 in.) x D534 mm (21.0 in.) Load: Max. 50 kg (110 lbs) /shelf	
	Stainless steel, dedicated central shelf Inner dimension: W615 mm (24.2 in.) x D461 mm (18.1 in.) Load; Max. 50 kg (110 lbs) /shelf		Stainless steel, dedicated central shelf Inner dimension: W855 mm (33.7 in.) x D461 mm (18.1 in.) Load: Max. 50 kg (110 lbs) /shelf	
Access port		Inner diameter: 17 mm (0.67 in.), 3 positions (back x 1, bottom x 2)		
Insulation		Rigid polyurethane foam + Vacuum insulation panel (VIP PLUS)		
Compressor		High stage side; Hermetic type, Output; 920 W Low stage side; Hermetic type, Output; 920 W		
Evaporator		High stage side; Cascade type, Low stage side; Tube on sheet type		
Condenser		High stage side; Fin and tube type, Low stage side; Brazing plate type		
Refrigerant		High stage side; R-290, Low stage side; R-170		
Temperature controller		Microcomputer control system		
Temperature display		LCD Digital display		
Thermal sensor		Platinum resistance (Pt 1,000 Ω)		
Alarm		High alarm, Low alarm, Power failure alarm, Internal communication error alarm, Compressor temp. abnormal alarm, Temperature Sensor disconnected/short-circuited alarm, Cascade temp. abnormal alarm, Door alarm		
Remote alarm contact		Allowable contact capacity: DC 30 V, 2 A ^{*1}		
Battery		Lead storage battery, DC 6 V, 7,000 mAh, Auto-recharge		
Weight		248 kg (547 lbs)	282 kg (622 lbs)	
Accessories		1 set of keys, 1 scraper, 1 stick for air intake port cleaning, 8 shelf stoppers		
Optional component		Temperature recorder (MTR-G85A, MTR-85H) Recorder fixing (MDF-S3085); For MTR-85H Recorder sensor cover (MTR-DU700SF) Backup cooling kit (MDF-UB7) ^{*2} ; For Liquid CO ₂ Inventory rack (IR-220U, IR-224U) Interface board (MTR-L03) ^{*1} ; For LAN Interface board (MTR-480) ^{*1} ; For RS-232C/RS-485		

*1: Standard signal and interface cables with a maximum length of 30 meters are recommended.

*2: Settable range of the injection start temperature is -70°C to -50°C.

Note:

Refer to the updated catalogue when ordering an optional component.

PERFORMANCE

Product name	Ultra-Low Temperature Freezer MDF-DU500ZHA	Ultra-Low Temperature Freezer MDF-DU700ZHA
Model number	MDF-DU500ZHA-PA	MDF-DU700ZHA-PA
Cooling performance	-86°C at the center of the chamber (ambient temperature; 30°C, no load)*	
Temperature settable range	-90°C to -40°C	
Temperature control range	-86°C to -40°C (ambient temperature; 30°C, no load)	
Rated voltage	AC 115 V	
Rated frequency	60 Hz	
Rated power consumption	375 W (Max. 930 W)	460 W (Max. 990 W)
Noise level	52 dB [A] (background noise; 20 dB)	
Maximum pressure	1,920 kPa	1,890 kPa
Heat emission	3,348 kJ/h	3,564 kJ/h
Environmental conditions	Ambient Temperature: 5°C to 30°C, Humidity: 80% RH or less	

* The value for the cooling performance indicates the lowest achievable temperature at the center of the chamber. For stable long-term use, it is recommended that the chamber temperature be set to at least 5°C higher than the lowest achievable temperature (-86°C). Depending on the actual use conditions, there may be a case where the chamber temperature does not reach the lowest achievable temperature (-86°C).

SAFETY ENVIRONMENTAL CONDITIONS

This equipment is designed to be safe at least under the following conditions (based on the IEC 61010-1):

- Indoor use;
- Altitude up to 2,000 m;
- Temperature 5°C to 40°C;
- Maximum relative humidity 80% for temperature up to 31°C decreasing linearly to 50% relative humidity at 40°C;
- Mains supply voltage fluctuations up to $\pm 10\%$ of the nominal voltage;
- Transient overvoltages up to the levels of OVERVOLTAGE CATEGORY II;
- Temporary OVERVOLTAGES occurring on the mains supply;
- Applicable pollution degree of the intended environment (POLLUTION DEGREE 2 in most cases);

* The above conditions do not indicate the performance of this product. For the performance of this product, refer to the "PERFORMANCE" section.

SAFETY CHECK SHEET



CAUTION

Please copy and fill out this form before servicing.
Hand over this form to the service engineer for their
and your safety.

Safety check sheet

1. Stored material

Risk of infection: Yes No Maybe

Risk of toxicity: Yes No Maybe

Risk from radioactive sources: Yes No Maybe

List all potentially hazardous materials that have been stored in this unit:

2. Contamination in the unit

a) Contamination Yes No Maybe

Types of contamination (if any): _____

b) Decontaminated Yes No

Methods used for the decontamination work:

3. Status of the unit

a) The unit is now safe to work on Yes No

b) If the answer is "No,"

Details on the danger: _____

Measures we should take to reduce the danger:

Date:

Signature:

Address, Division:

Telephone:

Product name:

Ultra-low temperature freezer

Model No.

MDF-

Serial number:

Date of Installation:

Please decontaminate the unit yourself before calling the service engineer.

MEMO

MEMO



PHC Corporation

1-1-1 Sakada, Oizumi-machi, Ora-gun, Gunma 370-0596, Japan

© PHC Corporation 2023



LDCL078100-1

Printed in Japan
LDCL078100-1
J0123-10523