

SMO FORCED AIR OVENS 230 Voltage



Installation - Operation Manual

SMO14-2 SMO28-2 SMO28G-2

These ovens require permanent connect wiring (also known as a hardwiring) to a power source

Pictured on Cover: Left to right SMO14-2 and SMO28-2

Warning: This product contains chemicals, including Triglycidyl Isocyanurate, known to the State of California to cause cancer as well as birth defects or other reproductive harm. For more information go to www.P65Warnings.ca.gov.



¡Advertencia! Este producto contiene sustancias químicas, incluido el triglicidil isocianurato, que el estado de California sabe que causa cáncer, así como defectos de nacimiento u otros daños reproductivos. Para obtener más información, visite www.P65Warnings.ca.gov.

Avertissement! Ce produit peut vous exposer à des produits chimiques, dont l'isocyanurate de triglycidyle, reconnu par l'État de Californie pour provoquer le cancer, des anomalies congénitales ou d'autres problèmes de reproduction. Pour plus d'informations, visitez le site www.P65Warnings.ca.gov

SMO Forced Air Ovens 230 Voltage

Part Number (Manual): 4861581

Revision: August 20, 2019

Note: The SMO28G-2 ships with two wire shelves typically used in curing applications. The SMO28G-2 is identical to the SMO28-2 in all other respects.



SHEL LAB is a brand of Sheldon Manufacturing, INC, an ISO 9001 certified manufacturer.



Safety Certifications

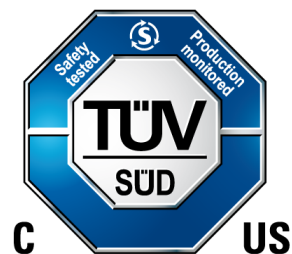

These units are CUE listed by TÜV SÜD as forced air ovens for professional, industrial, or educational use where the preparation or testing of materials is done at an ambient air pressure range of 22.14 – 31.3 inHg (75 – 106 kPa) and no flammable, volatile, or combustible materials are being heated.

These units have been tested to the following requirements:

- CAN/CSA C22.2 No. 61010-1:2012
- CAN/CSA C22.2 No. 61010-2-010 + R:2009
- UL 61010A-2-010:2002
- UL 61010-1:2012
- EN 61010-1:2010
- EN 61010-2-010:2003

TABLE OF CONTENTS

INTRODUCTION	5
<i>Read this Manual.....</i>	5
<i>Safety Considerations and Requirements</i>	5
<i>Contacting Assistance</i>	6
<i>Manufacturing Warranty</i>	6
<i>Engineering Improvements.....</i>	6
<i>Reference Sensor Device</i>	7
RECEIVING YOUR UNIT	9
<i>Inspect the Shipment.....</i>	9
<i>Orientation.....</i>	10
<i>Recording Data Plate Information</i>	13
INSTALLATION	15
<i>Hardwire Requirement.....</i>	15
<i>Installation Checklist</i>	15
<i>Required Ambient Conditions.....</i>	16
<i>Required Clearances.....</i>	16
<i>Power Source Requirements</i>	17
<i>Power Feed Wiring.....</i>	17
<i>Lifting and Handling</i>	18
<i>Removing from the Pallet.....</i>	18
<i>Leveling.....</i>	18
<i>Install the Oven</i>	19
<i>Installation Cleaning.....</i>	19
<i>Install the Shelving.....</i>	20
GRAPHIC SYMBOLS	21
CONTROL PANEL OVERVIEW	23
OPERATION.....	25
<i>Operating Precautions.....</i>	25
<i>Theory of Operation</i>	26
<i>Put the Oven into Operation</i>	28
<i>Set the Temperature Set Point.....</i>	29
<i>Set the Over Temperature Limit.....</i>	30
<i>Setting the Timer</i>	31
<i>Launching a Heating Profile.....</i>	33
<i>Drying Racks and other Accessories.....</i>	34
USER MAINTENANCE.....	35
<i>Cleaning and Disinfecting.....</i>	35
<i>Door Components.....</i>	36
<i>Electrical Components</i>	36
<i>Calibrating the Temperature Display.....</i>	37
UNIT SPECIFICATIONS	41
<i>Weight.....</i>	41
<i>Dimensions.....</i>	41
<i>Capacity</i>	41
<i>Shelf Capacity by Weight.....</i>	42
<i>Air Flow Performance.....</i>	42
<i>Temperature</i>	43
<i>Power.....</i>	44
PARTS LIST.....	45

INTRODUCTION

Thank you for purchasing a SHEL LAB oven. We know you have many choices in today's competitive marketplace when it comes to constant temperature equipment. We appreciate you choosing ours. We stand behind our products and will be here if you need us.

READ THIS MANUAL

Failure to follow the guidelines and instructions in this user manual may create a protection impairment by disabling or interfering with the unit safety features. This can result in injury or death.

Before using the unit, read the manual in its entirety to understand how to install, operate, and maintain the unit in a safe manner. Keep this manual available for use by all operators. Ensure all operators are given appropriate training before the unit begins service.

SAFETY CONSIDERATIONS AND REQUIREMENTS

Follow basic safety precautions, including all national laws, regulations, and local ordinances in your area regarding the use of this unit. If you have any questions about local requirements, please contact the appropriate agencies.

SOPs

Because of the range of potential applications this unit can be used for, the operator or their supervisors must draw up a site-specific standard operating procedure (SOP) covering each application and associated safety guidelines. This SOP must be written and available to all operators in a language they understand.

Locations and Intended Applications Range

SMO forced-air ovens are engineered for constant temperature forced-air drying, curing, and baking applications in professional, industrial, and educational environments. The ovens are not intended for use at hazardous or household locations.

Power

Your unit and its recommended accessories are designed and tested to meet strict safety requirements.

- Always hardwire the unit power feed to a protective earth-grounded electrical source that conforms to national and local electrical codes. If the unit is not grounded, parts such as knobs and controls may conduct electricity and cause serious injury.
- Position the unit so the end-user can quickly and easily disconnect or uncouple the power feed in the event of an emergency.
- Avoid damaging the power feed. Do not bend it excessively, step on it, place heavy objects on it. A damaged power feed can easily become a shock or fire hazard. Never use a power feed after it has been damaged.
- Use only approved accessories. Do not modify system components. Any alterations or modifications to your oven may be dangerous and will void your warranty.

INTRODUCTION

CONTACTING ASSISTANCE

Phone hours for Sheldon Technical Support are 6 am – 4:30 pm Pacific Coast Time (west coast of the United States, UTC -8), Monday – Friday. Please have the following information ready when calling or emailing Technical Support: the **model number, serial number, part number, and part ID** (see page 13).

support@sheldonmfg.com
1-800-322-4897 extension 4
(503) 640-3000 extension 4
FAX: (503) 640-1366

Sheldon Manufacturing, INC.
P.O. Box 627
Cornelius, OR 97113
USA

MANUFACTURING WARRANTY

For information on your warranty and online warranty registration please visit:

- sheldonmanufacturing.com/warranty

ENGINEERING IMPROVEMENTS

Sheldon Manufacturing continually improves all of its products. As a result, engineering changes and improvements are made from time to time. Therefore, some changes, modifications, and improvements may not be covered in this manual. If your unit's operating characteristics or appearance differs from those described in this manual, please contact your SHEL LAB dealer or customer service representative for assistance.

INTRODUCTION

REFERENCE SENSOR DEVICE

Must be purchased separately

A reference sensor device is required for calibrating the unit temperature display.

Reference devices must meet the following standards:

- Accurate to at least 0.1°C

The device should be regularly calibrated, preferably by a third party.

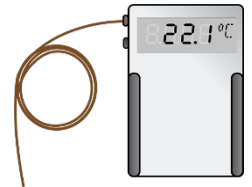

Temperature Reference

Temperature Probe

Use a digital device with a wire thermocouple probe that can be introduced into the unit chamber through the access port or door space. Select a thermocouple suitable for the application temperature you will be calibrating at.

Why a Probe?

Reference readings taken from outside the chamber using wire temperature probes avoid chamber door openings. Openings disrupt the chamber temperature. Each disruption requires **a minimum 1-hour wait** to allow the chamber to re-stabilize before continuing.

No Alcohol or Mercury Thermometers

Alcohol thermometers do not have sufficient accuracy to conduct accurate temperature calibrations. **Never place a mercury thermometer in the unit chamber.** Always use thermocouple probes.

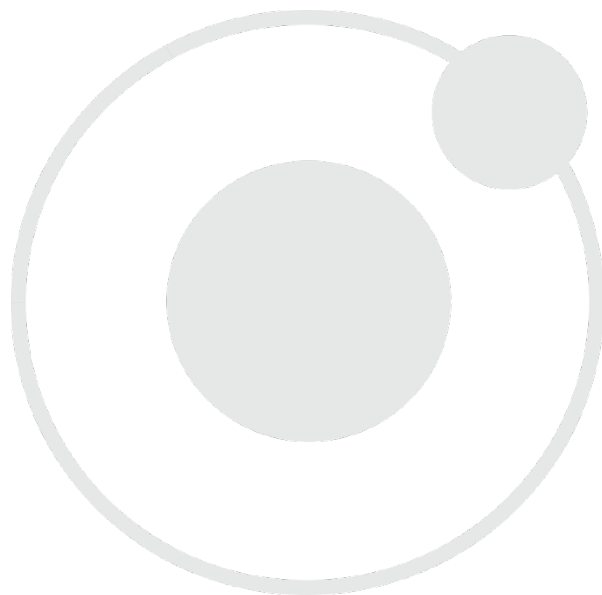

RECEIVING YOUR UNIT

INSPECT THE SHIPMENT

When a unit leaves the factory, safe delivery becomes the responsibility of the carrier. **Damage sustained during transit is not covered by the manufacturing defect warranty.**

When you receive your unit, inspect it for concealed loss or damage to its interior and exterior. If you find any damage to the unit, **follow the carrier's procedure for claiming damage or loss.** Save the shipping carton until you are certain that the unit and its accessories function properly.

1. Carefully inspect the shipping carton for damage.
2. Report any damage to the carrier service that delivered the unit.
3. If the carton is not damaged, open the carton and remove the contents.
4. Inspect the unit for signs of damage. Use the orientation images in this chapter as references.
5. The unit should come with an Installation and Operation Manual.
6. Verify that the correct number of accessory items has been included.
7. Carefully check all packaging for accessory items before discarding.

Included Components:

Model	Shelves	Shelf Clips	Leveling Feet
SMO14-2	3	12	4
SMO28-2	6	24	4

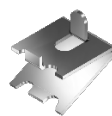

Model	Shelves	Shelf Clips	Leveling Feet
SMO28G-2	2	8	4

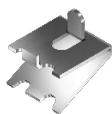
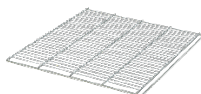

RECEIVING YOUR UNIT

ORIENTATION

SMO28-2

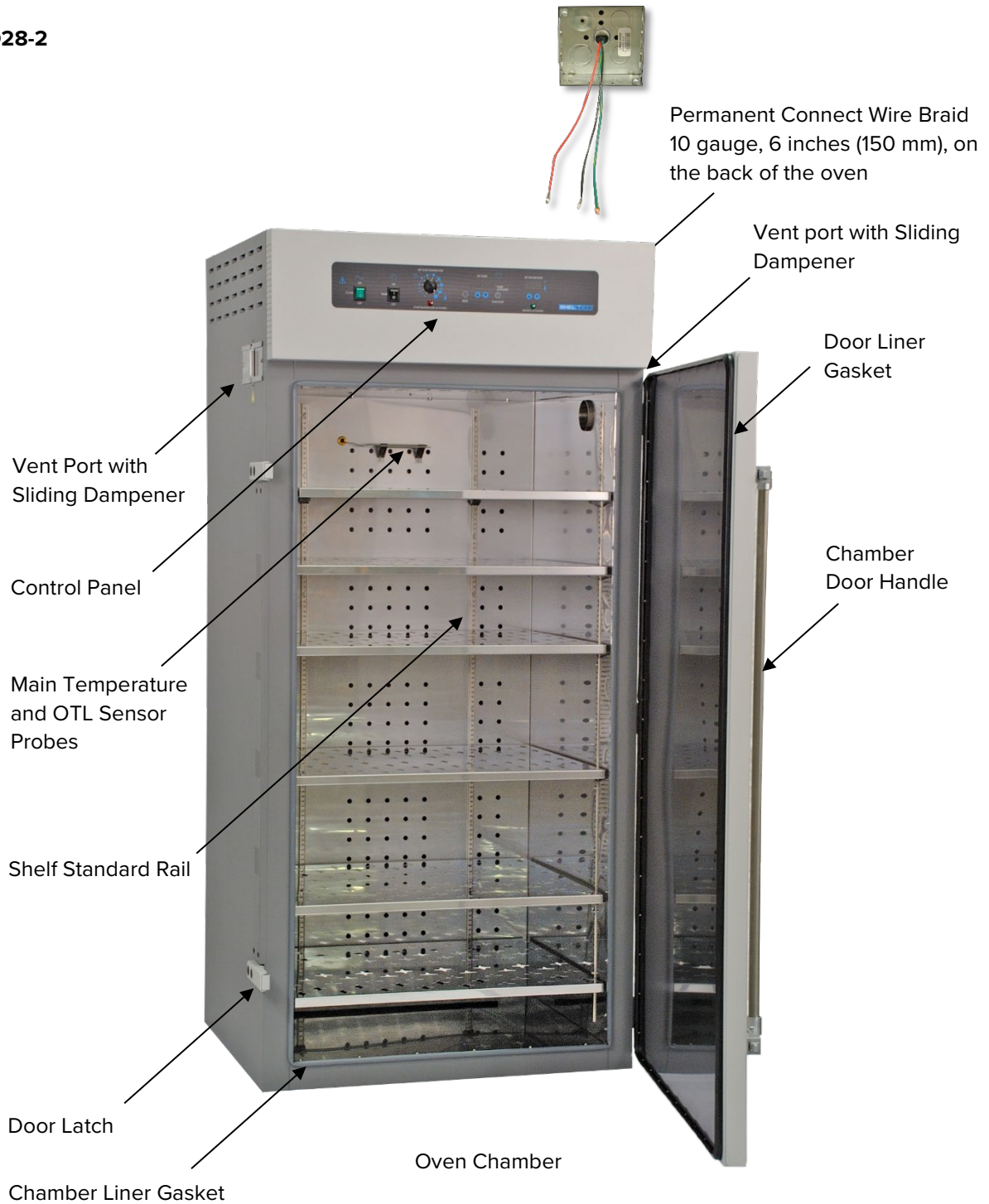

RECEIVING YOUR UNIT

SMO28G-2

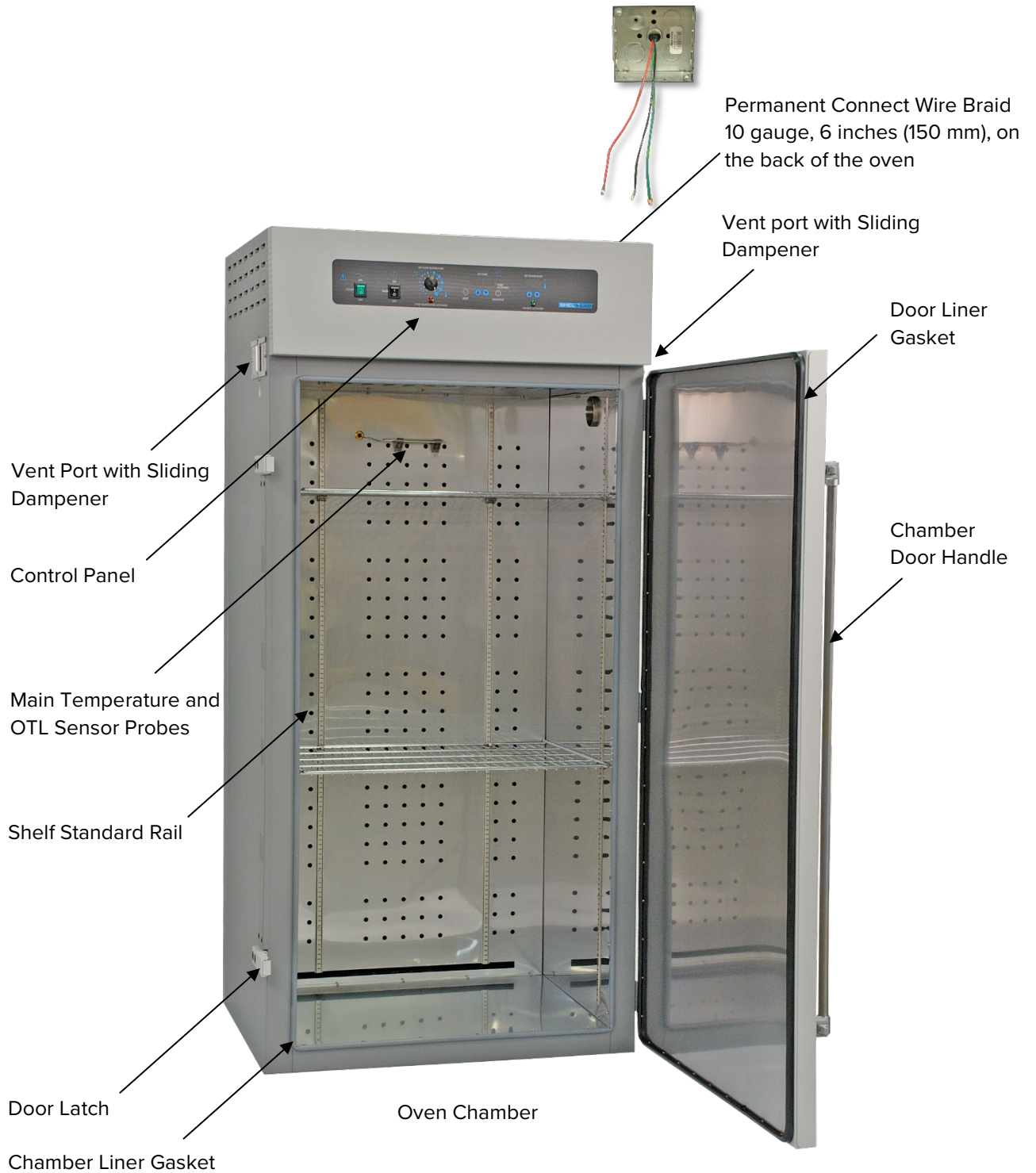

RECEIVING YOUR UNIT

SMO14-2

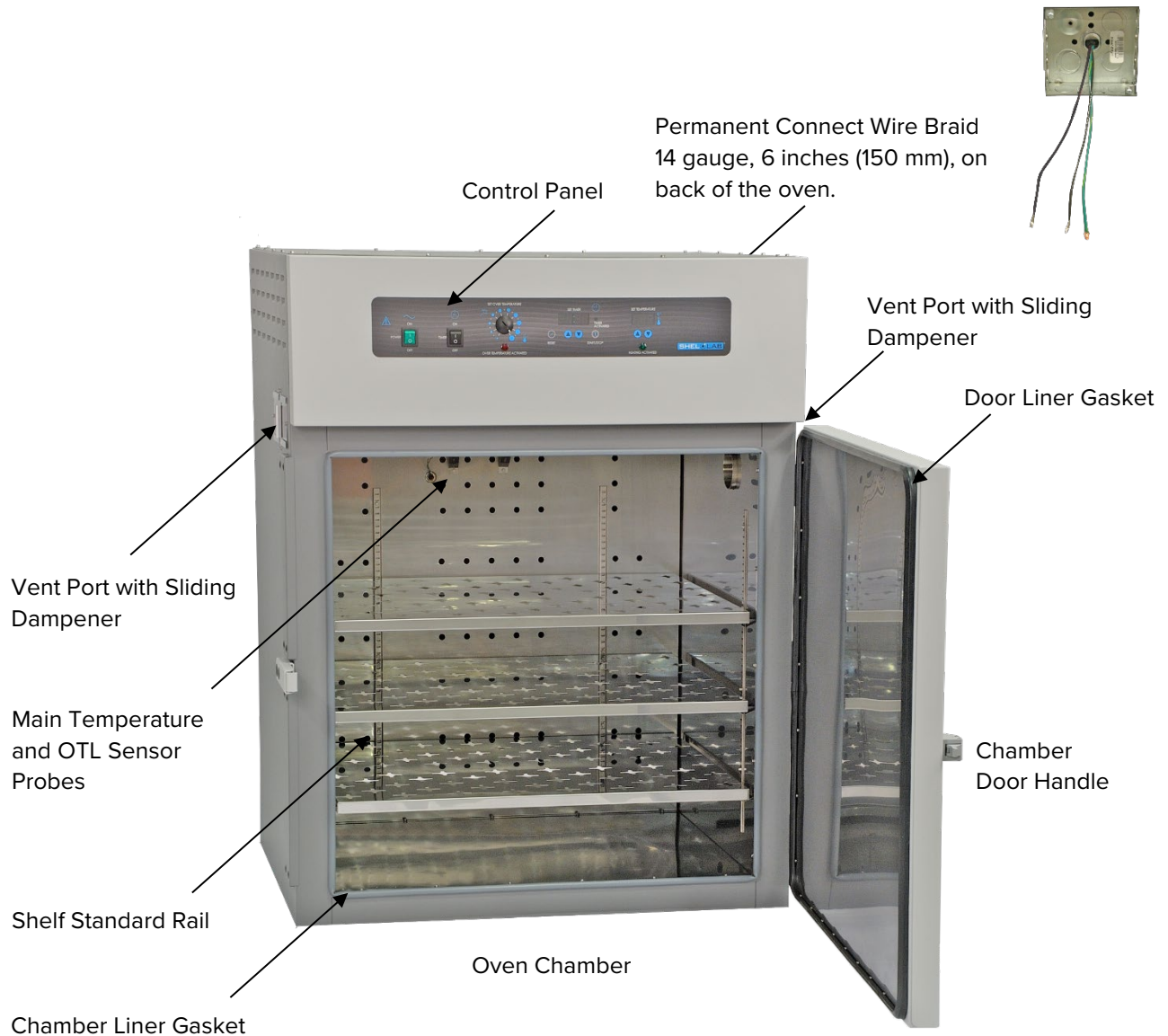

RECEIVING YOUR UNIT

RECORDING DATA PLATE INFORMATION

Record the unit **model number**, **serial number**, **part number**, and **part ID** below for future reference. Tech Support needs this information to provide accurate help during support calls and emails.

- The data plate with this information is located on the back of the oven below the power braid inlet.

MODEL NO:	
SERIAL NO:	
PART NO:	
PART ID:	

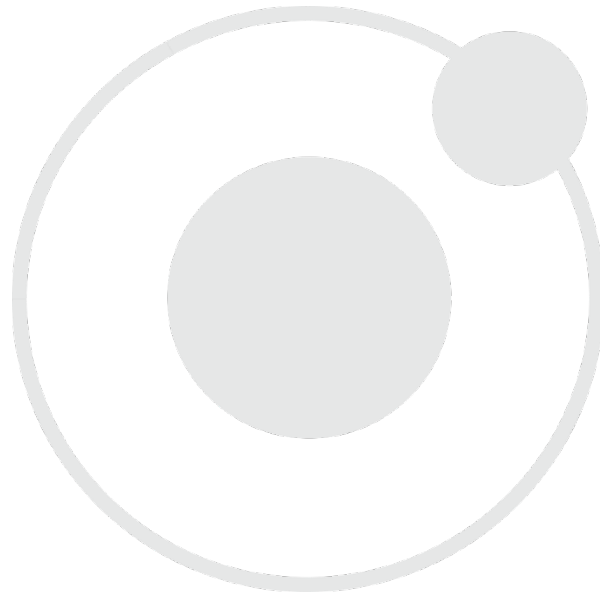

HARDWIRE REQUIREMENT

The oven requires permanent connect wiring (commonly known as hardwiring). Wiring to the power source **must be performed by a qualified electrical technician**. All other Installation steps may be performed by the end-user.

INSTALLATION CHECKLIST

For installing the unit in a new workspace location

Pre-Installation

- ✓ Check that the required ambient condition for the oven are met, page 16
- ✓ Check that the spacing clearance requirements are met, page 16
 - Unit dimensions may be found on page 41
- ✓ Check for performance-disrupting heat and cold sources in the environment, page 16
- ✓ Check that a suitable permanent connect electrical power supply is present, page 17

Install the Oven in its Workspace Location

- ✓ Review the lifting and handling instructions, page 18
- ✓ Make sure the oven is level, page 18
- ✓ Install the oven in its workspace location, page 19

Set up the Oven for Use

- ✓ Clean the oven chamber and shelving if needed, page 19
- ✓ Install the shelving in the oven chamber, page 20

INSTALLATION

REQUIRED AMBIENT CONDITIONS

This oven is intended for use indoors, at room temperatures between **15°C and 40°C (59°F and 104°F)**, at no greater than **80% Relative Humidity** (at 25°C / 77°F). Operating the unit outside of these conditions may adversely affect its temperature range and stability.

When selecting a location to install the unit, consider all environmental conditions that can affect its temperature performance. For example:

- Proximity to other ovens, autoclaves, and any device that produces significant radiant heat
- Heating and cooling ducts, or other sources of fast-moving air currents
- High-traffic areas
- Direct sunlight

REQUIRED CLEARANCES

These clearances are required to provide air flows for ventilation and cooling

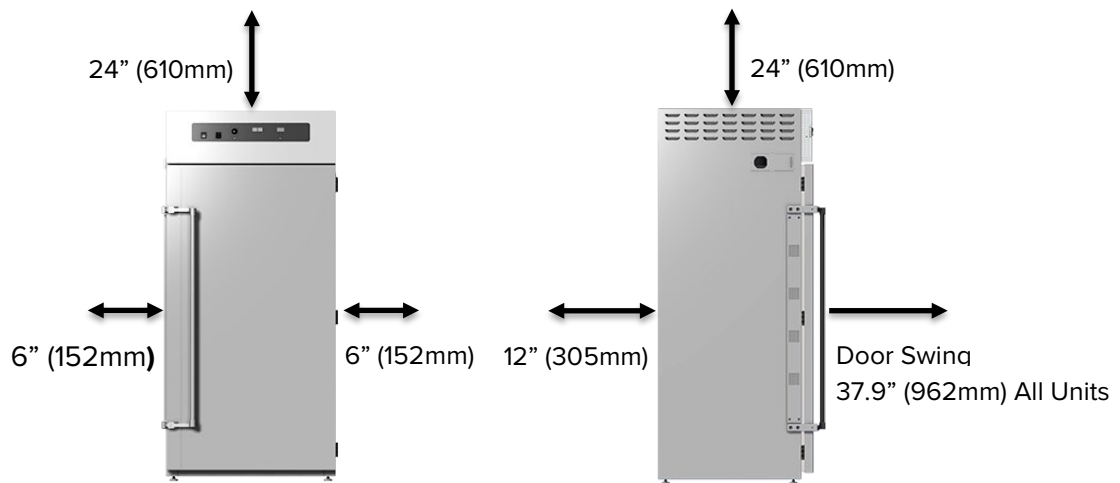

- **24 inches (610 mm)** of vertical headspace clearance.
 - Do not place objects on top of the oven.
- **6 inches (152 mm)** of space on the left and right side.
- **12 inches (305 mm)** space from the back of the oven.
 - Allow at least **6 inches (152 mm)** fan vent on the back of the oven to the nearest wall or partition.
 - The fan vent must be unobstructed at all times.

INSTALLATION

POWER SOURCE REQUIREMENTS

When selecting a location for the oven, check that each of the following requirements is satisfied:

Power supply: The power supply must meet the power requirements listed on the oven data plate (located on the back of the unit, beneath the power feed inlet. These ovens are intended for a **230 volt, 50/60 Hz** applications at the following amperages:

Model	Amperage	Model	Amperage
SMO14-2	12	SMO28-2	20

- The power source must be **single (1) phase** and **protective earth grounded**.
- The power source must conform to all national and local electrical codes.
- **Supplied voltage must not vary more than 10% from the data plate rating.** Damage to the oven may result if the supplied voltage varies more than 10%.
- Use a separate circuit to prevent loss of the unit due to overloading or circuit failure. The circuit must meet or exceed the amperage requirements listed on the oven data plate.

Switch or circuit-breaker: A switch or circuit-breaker must be used in the building installation to protect against overcurrent conditions.

- The required circuit-breakers are,
 - SMO14-2 **15A**; SMO28-2 SMO28G-2 **30A**.

Power feed disconnect: The oven must be positioned so that all operators have access to the power feed disconnect in case of emergencies.

- The Disconnect must be in close proximity to the equipment and within easy reach of the operator.
- The Disconnect must be marked as the disconnecting device for the equipment.

POWER FEED WIRING

The oven comes provided with an integral 6 inch (150 mm) wire braid of:

- SMO14-2 – Two 14-gauge high-temperature (300°C) hot wires and a 14-gauge earth ground.
- SMO28-2 SMO28G-2 -- Two 10-gauge high-temperature (300°C) hot wires and a 10-gauge earth ground.

The wires for power source connection should be in accordance with the following:

- SMO14-2: Green/Yellow – Earth; Red – Hot; Black – Hot.
- SMO28-2 SMO28G-2: Green/Yellow – Earth; Black – Hot; Black – Hot.

The oven must be grounded using the protective conductor terminal (green with yellow stripe wire). Do not remove the protective conductor (earth connection). Removing the protective conductor will negate the oven protections against potentially dangerous electric shocks and create a possible fire hazard.



INSTALLATION

LIFTING AND HANDLING

The oven is heavy. Use appropriate lifting devices that are sufficiently rated for these loads. Follow these guidelines when lifting the oven:

- Lift the oven only from its bottom surface.
- Doors, handles, and knobs are not adequate for lifting or stabilization.
- Restrain the oven completely while lifting or transporting so it cannot tip.
- Remove all moving parts, such as shelves and trays, and lock doors in the closed position during transfers to prevent shifting and damage.

REMOVING FROM THE PALLET

The unit comes secured to a shipping pallet with ½” hex bolts inserted through the 4 leveling feet holes on the bottom of the incubator. Use a socket wrench to remove the bolts and release the unit from the pallet.

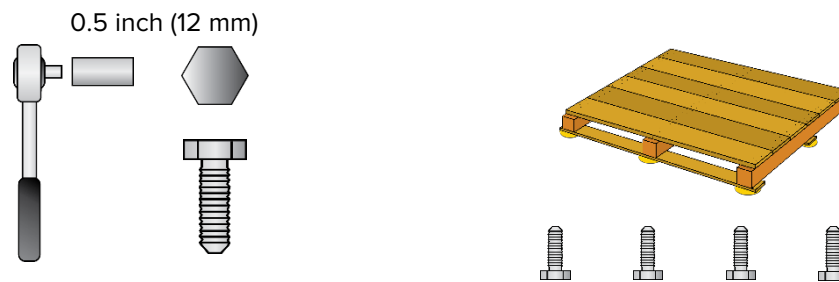

LEVELING

Install the 4 leveling feet with the 4 corner holes on the bottom of the unit. The unit must be level and stable for safe operation.

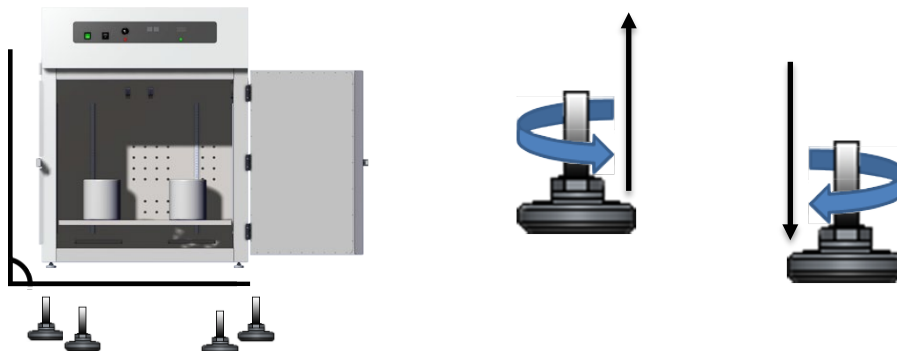

Note: To prevent damage when moving the unit, turn all four leveling feet so that the leg of each foot sits inside the unit.

INSTALL THE OVEN

Place the unit in a workspace location that meets the criteria discussed in the previous entries of the Installation section.

- Verify that the oven stands level and does not rock. Adjust the leveling feet as needed.
- **Power:** The oven may now be hardwired to its power source



INSTALLATION CLEANING

The manufacturer recommends cleaning the shelving and chamber prior to installation of the shelving in the chamber.

- The unit was cleaned at the factory but may have been exposed to contaminants during shipping.
- Remove all wrappings and coverings from shelving prior to cleaning and installation. **Do not clean the shelving with deionized water.**
- Please see the [Cleaning and Disinfection](#) procedure on page 35 in the User Maintenance chapter for information on how to clean and disinfect without damaging the unit.

INSTALLATION

INSTALL THE SHELVING

Airflow: The horizontal airflow in the chamber moves from the duct holes in the back-chamber wall, across the shelf space to the front. To maximize air flow, avoid obstructing the duct holes as much as possible when placing shelves.

Spacing: Space the shelves evenly in the oven chamber to ensure the best possible temperature uniformity.

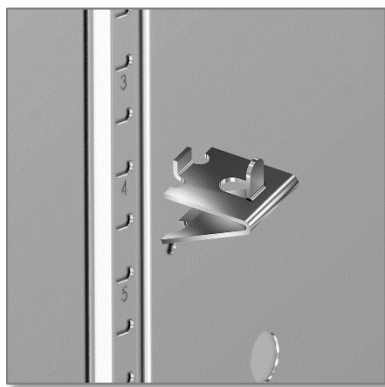

Installing a Shelf Clip

Rocking Motion

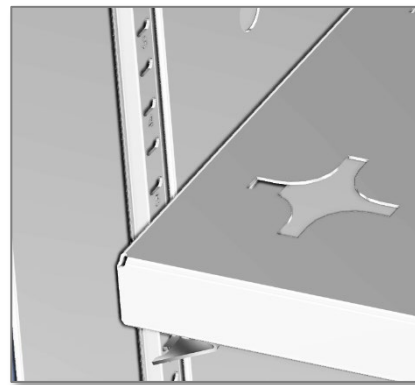









Shelf Set on Clips

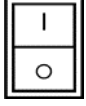

1. Install 4 shelf clips in 4 slots on the shelf standard rails. These mounting rails are located on the left, right, and rear walls of the chamber interior.
 - a. Squeeze each clip.
 - b. Insert the top tab first, then the bottom tab using a rocking motion.
 - c. The slots must all be at equal height to hold the shelf level.
2. Place the shelf on the clips.

GRAPHIC SYMBOLS

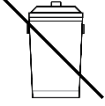
The oven is provided with multiple graphic symbols on its exterior. The symbols identify hazards and the functions of the adjustable components, as well as important notes in the user manual.

Symbol	Definition
	Consult the user manual. Consulter le manuel d'utilisation
	Indicates Temperature Repère température
	Indicates the Over Temperature Limit system Indique le système de dépassement de température
	AC Power Repère le courant alternatif
	I/ON O/OFF I indique que l'interrupteur est en position marche. O indique que le commutateur est en position d'arrêt.
	Protective earth ground Terre électrique
	Indicates UP and DOWN respectively Touches de déplacements respectifs vers le HAUT et le BA
	Indicates a Manually Adjustable control Indique un bouton réglable manuellement
	Potential shock hazard Risque de choc électrique
	Recycle the unit. Do not dispose of in a landfill. Recycler l'unité. Ne jetez pas dans une décharge.

GRAPHIC SYMBOLS

Symbol	Definition
	Indicates the timer Indique le minuterie
	Start or Stop the Timer Lancer ou arrêter le minuteur
	Reset the Timer Réinitialisation de la Minuterie
	Caution hot surface Attention surface chaude

CONTROL PANEL OVERVIEW



Control Panel

Power Switch

The green Power Switch controls overall power to the oven. When in the ON (I) position the switch illuminates and the oven will heat to and maintain the currently programmed temperature set point.



Timer Switch

The black Timer Switch controls power to the timer system. When this switch is in the ON position the SET TIMER display will illuminate, and the oven can run a timed steady-state heating profile at the current temperature set point. The oven **will not heat** while the Timer system is on unless a profile is running.



Over Temperature Limit Control (OTL)

This graduated dial sets the temperature limit for the Over Temperature Limit system. The OTL is an independent mechanical heating cutoff that prevents unchecked heating of the oven in the event of a failure of the main temperature controller system. For more details, please see the explanation of the [Over Temperature Limit System](#) on page 27 in the Theory of Operation entry.

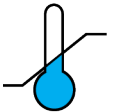

OTL Light

Marked OVER TEMP ACTIVATED, this light illuminates whenever the OTL System is routing power away from the heating elements. Under normal operating conditions this light should never illuminate.



Timer Display and Control Pad

The SET TIMER display can show the duration of the currently programmed heating profile, or a flashing duration adjustment mode, or the countdown of a running profile to 0.



The “//” RESET button is used to place the Timer display in its adjustable duration mode, and then to scroll through the duration time parameters.



The black SET TIMER arrow buttons adjust the heating profile duration time parameters when the display is in its blinking adjustment mode.



The “T” START/STOP timer button launches a heating profile or pauses a running profile.



CONTROL PANEL



Main Temperature Display and Control

Marked SET TEMPERATURE, this display shows the current oven chamber air temperature accurate to 1°C. The display can also show an adjustable temperature set point in the display's set point mode, as well as an adjustable offset while in calibration mode.



The arrow buttons can be used to adjust the temperature set point or place the unit in its calibration mode, and then enter a calibration offset value.

Heating Activated Light



The green pilot light located beneath the label HEATING ACTIVATED illuminates whenever the workspace oven heating elements are powered and warming the oven. The oven uses measured pulses to achieve and maintain the temperature set point.

Safe operation of the oven is dependent on the actions and behavior of the oven operators.

Operating personnel must read and understand the Operating Precautions in this section prior to operating the oven. The operators must follow these instructions to prevent injuries and to safeguard their health, environment, and the materials being treated in the oven, as well as to prevent damage to the oven. Failure to adhere to Operating Precautions, deliberately or through error, is a hazardous behavior on the part of the operator.



Le fonctionnement sûr du four dépend des actions et du comportement des opérateurs du four. Le personnel d'exploitation doit lire et comprendre les consignes de sécurité et les précautions d'utilisation de cette section avant d'utiliser le four. Les opérateurs doivent suivre ces instructions pour prévenir les blessures et protéger leur santé, leur environnement et les matériaux traités dans le four, ainsi que pour éviter d'endommager le four. Le non-respect des consignes de sécurité et des précautions d'utilisation, délibérément ou par erreur, est un comportement dangereux de la part de l'opérateur.



OPERATING PRECAUTIONS

- Do not use this oven in unsafe improper applications that produce flammable or combustible gasses, vapors, liquids, or fuel-air mixtures in quantities that can become potentially explosive.
- Outgassed byproducts may be hazardous to or noxious for operating personnel. Exhaust should be vented to a location outside the workspace in a safe manner in accordance with all applicable laws, ordinances, and regulations. Do not operate the oven in an unsafe area with noxious fumes.
- Do not use this oven for applications heating hazardous fibers or dust. These items can become airborne and come into contact with hot surfaces.
- Individual ovens are not rated to be explosion proof. Follow all building certification requirements and laws for Class I, II, or III locations as defined by the US National Electric Code.
- The bottom surface of the chamber should not be used as a work surface. It runs hotter than the shelf temperatures. Never place samples or product on the oven chamber floor.
- Do not place sealed or filled containers in the oven. These may burst open when heated.
- Do not place alcohol or mercury thermometers in the oven. These devices may rupture under heat or other improper uses.
- Do not move the oven until it has finished cooling.

Warning: The vent dampers may be hot to the touch. These areas are marked with Hot Surface labels. Proper PPE should be employed to minimize risk to burn.

Avertissement: Les clapets d'aération peuvent être chauds au toucher. Ces zones sont marqués avec des étiquettes de Surface chaude. Les EPI approprié devraient être employée pour réduire au minimum le risque de brûler.



THEORY OF OPERATION

Heating



The oven temperature controller stores an end-user-selected constant temperature set point. When powered, the oven heats the chamber atmosphere to the set point. The controller board is wired to a solid-state temperature probe located in the chamber on the rear wall. When the controller detects that the chamber temperature has dropped below the temperature set point, it pulses power to the heating elements.

The controller uses proportional-integral-derivative analytical feedback-loop functions when measuring and controlling the chamber air temperature. PID-controlled heating pulse intensities and lengths are proportional to the difference between the measured chamber temperature and the current set point. The frequency of pulses is derived from the rate of change in the difference. The integral function slows the rate of pulses when the temperature nears the set point to avoid overshooting.

The oven relies on natural heat radiation for cooling. The oven can achieve a low-end operating temperature of the ambient room temperature plus the internal waste heat of the oven.

Air Circulation



The oven continually circulates air internally while powered. Air is forced through vent holes at the back of the chamber, blows across the shelf space to the front, and is then pulled upward into a heating and recirculation air duct by the action of the blower fan.

The oven is provided with two vents that may be opened or closed using dampener slides located on the oven exterior. **SMO forced air ovens must be run with the dampeners closed in order to achieve the stated chamber temperature uniformity and stability.**

The dampeners are intended to speed drying or evaporation rates after the heated portion of an application is complete. Opening the dampener vents while the oven is running may speed the rate of material drying, dependent on the nature of your application. However, running the oven with the dampeners open introduces cool air into the chamber while allowing heated air to exit. This may impact the temperature uniformity and stability of the chamber, and lower the operational temperature ceiling.

Timed Heating Profile

The oven is provided with a Timer subsystem that, when set, runs the oven in a steady-state heating profile at the current temperature set point from 1 minute up to 99 hours, 59 minutes. Allow the oven to heat to temperature prior to launching a profile. Launching a profile with the temperature set point set to 150°C immediately after turning on the oven will result in the first several minutes of the profile spent with the chamber rising from room temperature to 150°C.



When the Timer system is on, **the oven will not heat** unless a profile of 1 minute or greater has been launched.

The Over Temperature Limit System (OTL)

When set, the mechanical OTL heating cutoff system prevents runaway heating in the oven chamber. The OTL operates independently of the microprocessor and is provided with a separate, hydrostatic temperature sensor probe located in the oven chamber. In the event the chamber air temperature exceeds the current OTL setting, the OTL routes power away from the heating elements. The OTL will continue to prevent heating until the temperature drops below its limit setting.

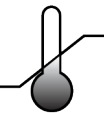

The Over Temperature Limit is set **by the end-user**, typically at approximately 5°C above the application temperature set point. The system is intended to protect the oven from damage.

PUT THE OVEN INTO OPERATION

Carry out the following steps and procedures to put the oven into operation after installing it in a new workspace environment.



1. Turn on the oven by placing the green main power switch in the (I) ON position.

2. Perform the following procedures:



- [Set the Oven Temperature Set Point](#) page 29



- [Set the Over Temperature Limit](#) page 33



- **Optional:** Set the oven timer to run the oven for a set duration. Please see page 31.

SET THE TEMPERATURE SET POINT

Adjust the oven temperature set point to that of your application.



1. Set OTL control to its maximum setting, if not already set to max.



- Turning the OTL all the way to the right (clockwise) prevents the heating cutoff system from interfering with this procedure.

2. Jump to the Temperature Set Point Adjustment mode



OR



Press and hold either

Set Temperature



Set Point Adjustment Mode

Set Temperature



Initial Set Point

Note: The display will automatically exit the adjustment mode after 5 seconds of inactivity on the arrow keys, saving the last shown set point value.

3. Set the Temperature Set Point



OR



Adjust



New Set Point

4. Wait for 5 seconds after entering the Set Point



Wait 5 Seconds

Set Temperature



HEATING ACTIVATED

- The display will stop flashing. The set point is now saved in the controller.
- The display will revert to showing the current chamber air temperature, heating or passively cooling to match the new set point.

Set the OTL when then the oven reaches the set point temperature. See next page.

End of Procedure

OPERATION

SET THE OVER TEMPERATURE LIMIT

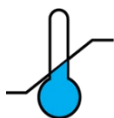

This procedure sets the Over Temperature Limit heating cutoff to approximately 5°C above the current oven chamber temperature. Perform the steps below once the oven has **been stabilized at your application temperature set point for at least 30 minutes**.

1. Set OTL control to its maximum setting, if not already set to max.

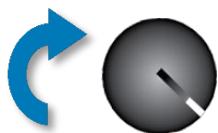

2. Turn the dial counterclockwise until the red Over Temperature Limit Light illuminates.



3. Slowly turn the dial clockwise until the OTL Activated light turns off.



- The Over Temperature Limit is now set approximately 5°C above the current chamber temperature.

4. Leave the OTL dial set just above the activation point.



Optional: Turn the dial slightly to the left.



- This sets the OTL cutoff threshold nearer to the current chamber temperature.

If the OTL is sporadically activating, you may turn the dial very slightly to the right (clockwise).

If the OTL continues activating, check for ambient sources of heat or cold that may be adversely impacting the unit temperature stability. If you can find no sources of external or internal temperature fluctuations, contact Tech Support or your distributor for assistance.

End of Procedure

SETTING THE TIMER

This procedure enters a heating profile duration in the Timer system. When launched, the profile runs the oven for the duration at the present temperature set point.



1. Turn on the Timer System

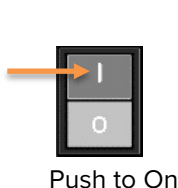

- The **Timer Display** will illuminate, showing the previously programmed profile duration.
- The oven will cease heating

2. Place the Timer Display in its adjustable Set Timer mode



- After approximately 3 seconds a flashing decimal point will appear after the hours parameter.

Note: If 5 seconds elapse with no activity on the Arrow Pad buttons, the Timer Display will exit the adjustment mode with the last entered time values saved.

3. Set the Hour parameter

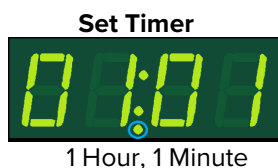
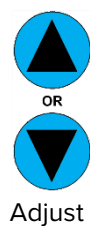

4. Advanced to Tens-of-Minutes parameter

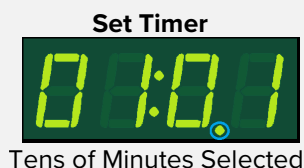

Note: Advancing saves the adjusted hour parameter.

Continued next page

OPERATION

Setting the Timer Continued



5. Set the Tens-of-Minute parameter



OR



Adjust

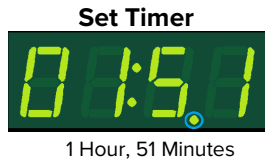

6. Advance to the Minutes parameter



Push

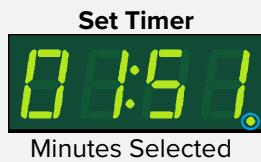

- The flashing decimal point will advance to between the third and fourth numbers, saving the new Tens-of-Minutes parameter setting

7. Set the Minutes parameter



OR



Adjust

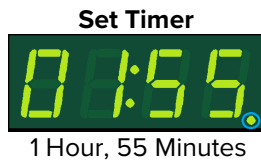

8. Wait for 5 seconds after entering the Minutes parameter



Wait 5 Seconds



- The display will exit adjustment mode.
- The Minutes parameter is now saved.

End of procedure

LAUNCHING A HEATING PROFILE

The oven can be run in a timed steady-state heating profile at the current temperature set point. Allow the oven to come up to temperature prior to launching a profile. See the [Setting the Timer procedure](#) on page 31 for how to set the length of the profile.



Note: While the Timer system is on, the oven will **not** heat unless a profile is running.

1. Turn on the Timer System

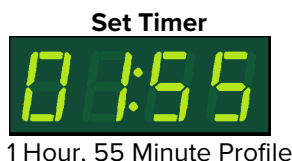
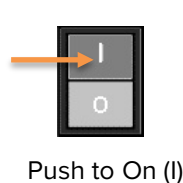

- The **Timer Display** will illuminate, showing the previously programmed profile duration.
- The oven will cease heating

2. Launch the current profile

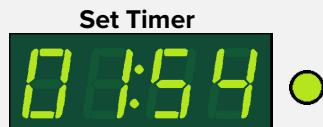
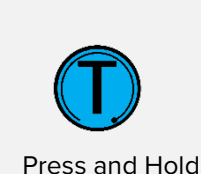

- The Timer Activated light illuminates and the Display will start counting down.
- The oven will resume heating.

Optional: Pausing a running profile



- The oven will cease heating until the profile is restarted, reset, or the Timer system is turned off.
- To restart the profile where it left off, press the **Start/Stop** “T” button again.

3. The oven ceases heating upon reaching “00:00”



- To resume manual heating place the **Timer Switch** in the OFF (O) position.
- To launch another profile, press the “//” **Reset** button and enter a new profile, or allow the previous profile to reset automatically after 5 seconds.

End of procedure

DRYING RACKS AND OTHER ACCESSORIES

Make sure that any accessories used inside the oven chamber, such as drying racks, are suitable for your application and will not suffer damage when brought to temperature. Always set the OTL cutoff system to approximately 5°C above your application temperature set point in order to safeguard accessories against over temperature events. The manufacturing defect warranty does not cover damage caused by melted or otherwise overheated accessory items.

Warning: Prior to maintenance or service on this unit, disconnect the power feed from the power supply.

Avertissement: Avant d'effectuer toute maintenance ou entretien de cet appareil, débrancher le cordon secteur de la source d'alimentation.



CLEANING AND DISINFECTING

If a hazardous material or substance has spilled in the oven, immediately initiate your site Hazardous Material Spill Containment protocol. Contact your local Site Safety Officer and follow instructions per the site policy and procedures.

- Periodic cleaning is required.
- Do not use spray on cleaners or disinfectants. These can leak through openings and coat electrical components.
- Consult with the manufacturer or their agent if you have any doubts about the compatibility of decontamination or cleaning agents with the parts of the equipment or with the material contained in it.
- Do not use cleaners or disinfectants that contain solvents capable of harming paint coatings or stainless steel surfaces. **Do not use chlorine-based bleaches or abrasives; these will damage the chamber liner.**

Warning: Exercise caution if cleaning the unit with alcohol or flammable cleaners. Always allow the unit to cool down to room temperature prior to cleaning and make sure all cleaning agents have evaporated or otherwise been completely removed prior to putting the unit back into service.

Avertissement: Soyez prudent lorsque vous nettoyez l'appareil avec de l'alcool ou des produits de nettoyage inflammables. Laissez toujours refroidir l'appareil à la température ambiante avant le nettoyage et assurez-vous que tous les produits de nettoyage se sont évaporés ou ont été complètement enlevés avant de remettre l'appareil en service.



Cleaning

1. Disconnect the unit from its power supply.
2. Remove all removable interior components such as shelving and accessories.
3. Clean the unit with a mild soap and water solution, including all corners.
 - **Do not use an abrasive cleaner**, these will damage metal surfaces.
 - **Do not use deionized water to rinse or clean with.**
 - Take special care when cleaning around the temperature sensor probes in the chamber to prevent damage. Do not clean the probes.
4. Rinse with distilled water and wipe dry with a soft cloth.

Disinfecting

Disinfect the oven if algae, mold, bacteria, or other biological contaminants are an issue. For maximum effectiveness, disinfection procedures are typically performed after cleaning.

Keep the following points in mind when disinfecting the oven:

- Turn off and disconnect the unit to safeguard against electrical hazards.
- Disinfect the oven chamber using commercially available disinfectants that are non-corrosive, non-abrasive, and suitable for use on stainless steel and glass surfaces. Contact your local Site Safety Officer for detailed information on which disinfectants are compatible with your applications.
- If permitted by your protocol, remove all removable interior accessories (shelving and other non-attached items) from the chamber when disinfecting.
- Disinfect all surfaces in the chamber, making sure to thoroughly disinfect the corners. Exercise care to avoid damaging the sensor probes.

When disinfecting external surfaces, use disinfectants that will not damage painted metal, glass, and plastic

DOOR COMPONENTS

Periodically, inspect the door latch, trim, and catch for alignment. Check the two silicon rubber gaskets located on the door and on the doorframe of the oven body for signs of drying, brittleness or cracking. Failure to maintain the integrity of the door system shortens the lifespan of the oven and may adversely impact chamber temperature uniformity and stability.

Replacement of the door liner and chamber liner gaskets is a service-level procedure.

ELECTRICAL COMPONENTS

Electrical components do not require maintenance. If the unit electrical systems fail to operate as specified, please contact your distributor or Technical Support for assistance.

CALIBRATING THE TEMPERATURE DISPLAY

Note: Please see the [Reference Sensor Device entry](#) on page 7 for the minimum device requirements.

Temperature calibrations match the oven temperature display to the actual air temperature inside the oven chamber. The actual air temperature is supplied by a reference sensor device. Calibrations compensate for software drifts in the controller as well as deviations caused by the natural material evolution of the sensor probe in the heated chamber space. Calibrate as often as required by your laboratory or production protocol, or regulatory compliance schedule. Always calibrate to the industry or regulatory standards required for your application.

- The probe may also be introduced through the chamber door space.

A Suggested Calibration Set Up



Use non-marking heat-resistant polyamide tape to hold the thermocouple probe in place. The oven manufacturer recommends Kapton brand tape, 0.5 inches width (12.7 mm), 2 mil thickness.

1. Introduce the reference device thermocouple sensor probe into the oven chamber through the right side vent.

- At least 12 inches (305mm) of wire must be in the oven chamber to prevent heatsinking, resulting in an false low temperature reading.

2. Place the sensor probe head as close to the geometric center of the oven chamber as possible.

- The probe head must be at least 2 inches (50 mm) from the surface of the shelving to prevent heatsinking.
- Secure with non-stick, heat-resistant tape.

3. Carefully close the sliding vent dampener. Use the tape to cover any gaps left by the presence of the wire.

4. Close and latch the oven chamber door. Failure to do so will result in an inaccurate calibration.

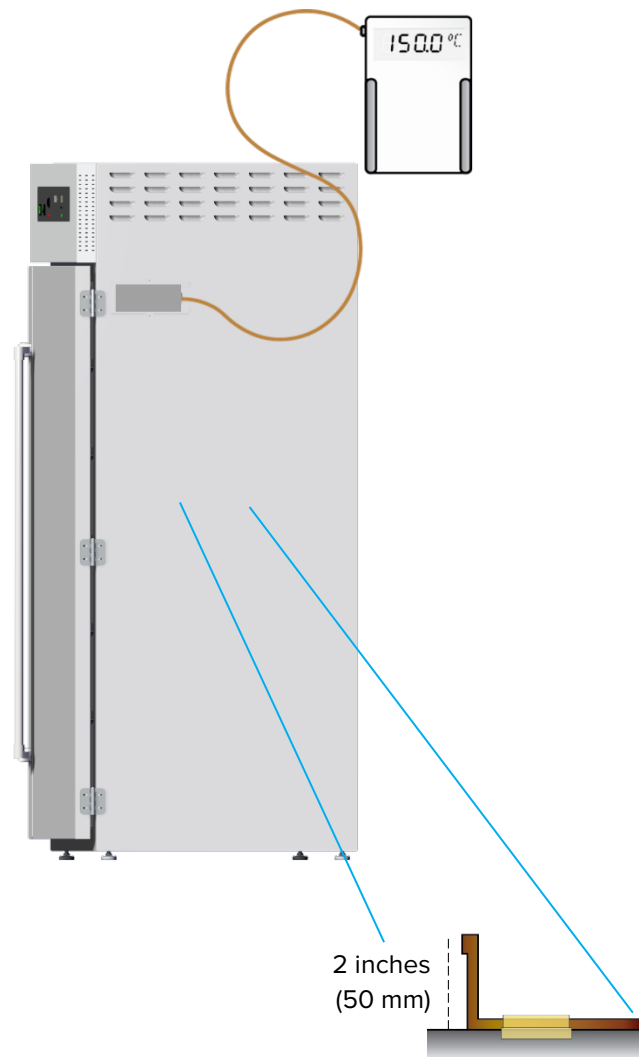

USER MAINTENANCE

5. Heat up and stabilization period.

- The oven chamber must be stable at temperature in order to perform an accurate calibration.
- The temperature is considered stabilized when the oven chamber has operated at your calibration temperature for at least **30 minutes with no fluctuations of $\pm 0.2^{\circ}\text{C}$ or greater.**

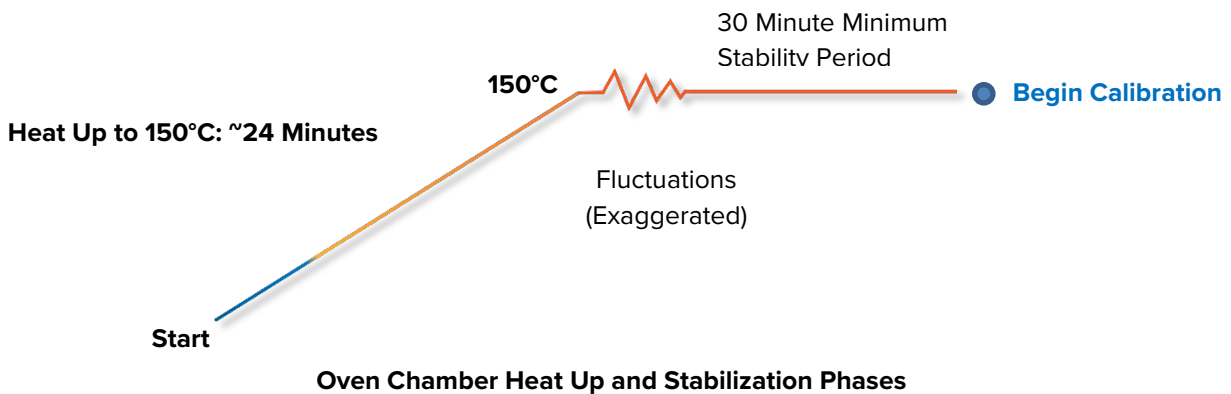

Suggested Calibration Procedure

1

Once the chamber has stabilized with no fluctuations, compare the reference temperature device and chamber temperature display readings.

- a. If the readings are the same, or the difference between the two falls within the acceptable range of your protocol, the display is accurately showing the chamber temperature. **The Temperature Calibration procedure is now complete.**

- Or -

- b. See Step 2 if a difference falls outside the acceptable range of your protocol.

Reference Device

88150 °C

Set Temperature

150 ✓

2

The display requires calibration. Advance to Step 3.

- If the door was opened to check a reference device temperature inside the chamber wait 15 minutes **after the reference device reading stops fluctuating** before proceeding.



Wait 15 Minutes

Reference Device

88148 °C

Set Temperature

150 X

Continued next page

USER MAINTENANCE

Calibration continued

3

Place the oven in temperature calibration mode.

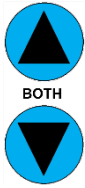

- a. Press and hold **both** the **UP** and **DOWN** arrow buttons simultaneously.
- The Temperature Display will show the letters “C O”, then begin flashing the **current temperature value**.

Set Temperature



Set Temperature



Current Temp. Value

Note: If an arrow key is not pressed for five seconds, the Temperature Display will cease flashing, and store the last displayed value as the new current chamber temperature value.

4



Adjust the current temperature value to match the reference device.

- a. Use the **UP** and **DOWN** arrow buttons.

Set Temperature



Corrected

Reference Device



5

After entering the correction adjustment, wait 5 seconds.



Wait 5 Seconds

- The temperature display will cease flashing and store the correction as an offset.
- The oven will now begin heating or allow itself to cool to reach your set point with the corrected display value.

Set Temperature



Heating with Corrected Value

6



Wait 30 Minutes

Wait for the oven to achieve the new set point with the corrected display value.

Set Temperature



Procedure continued on next page

USER MAINTENANCE

Calibration continued

7



After the oven has achieved the set point, wait for the oven chamber temperature to stabilize.

- The chamber temperature is stabilized when no fluctuations of 1°C or greater have been detected with the reference device for a minimum of 30 minutes.
- Failure to wait for stabilization will result in an inaccurate calibration.

Reference Device

150.0 °C

8

Once the temperature has stabilized, compare the reference device and the oven display temperature readings.

- a. If the readings are the same, or the difference between the two falls within the acceptable range of your protocol, **the oven is calibrated for temperature.**

-Or-

- b. Advance to step 9.

Reference Device

150.1 °C

Set Temperature

150 ✓

9

If the two readings still fall outside the acceptable range of your protocol, repeat steps 3 – 8 up to two more times.

- Three calibration attempts may be required to successfully calibrate ovens more than $\pm 2^{\circ}\text{C}$ out of calibration.

Reference Device

149.9 °C

Set Temperature

150 ✗

If the temperature readings of the oven and the reference device fall outside your protocol after three calibration attempts, contact [Technical Support](#) or your distributor for assistance.

End of procedure

UNIT SPECIFICATIONS

These ovens are 230 voltage units. Please refer to the oven data plate for individual electrical specifications.

Technical data specified applies to units with standard equipment at an ambient temperature of 25°C and at nominal voltage. The temperatures specified are determined in accordance with factory standard following DIN 12880 respecting the recommended wall clearances of 10% of the height, width, and depth of the inner chamber. All indications are average values, typical for units produced in the series. We reserve the right to alter technical specifications at all times.

WEIGHT

Model	Shipping	Net Weight
SMO14-2	361 lb / 164 kg	280.0 lb / 127.3 kg
SMO28-2	513 lb / 233 kg	390.0 lb / 177.3 kg
SMO28G-2	513 lb / 233 kg	390.0 lb / 177.3 kg

DIMENSIONS

By Inches

Model	Exterior W × D × H	Interior W × D × H
SMO14-2	37.5 x 34.0 x 48.0 in	30.8 x 24.8 x 31.0 in
SMO28-2	37.5 x 35.0 x 78.3 in	30.8 x 25.0 x 61.0 in
SMO28G-2	37.5 x 35.0 x 78.3 in	30.8 x 25.0 x 61.0 in

By Millimeters

Model	Exterior W × D × H	Interior W × D × H
SMO14-2	953 x 864 x 1219 mm	782 x 630 x 788 mm
SMO28-2	953 x 889 x 1989 mm	782 x 635 x 1575 mm
SMO28G-2	953 x 889 x 1989 mm	782 x 635 x 1575 mm

CAPACITY

Model	Cubic Feet	Liters
SMO14-2	13.7	388
SMO28-2	27.6	781
SMO28G-2	27.6	781

UNIT SPECIFICATIONS

SHELF CAPACITY BY WEIGHT

Model	Per Shelf	Total
SMO14-2	75.0 lb / 34.0 kg	225.0 lb / 102.0 kg
SMO28-2	75.0 lb / 34.0 kg	450.0 lb / 204.0 kg
SMO28G-2	30.0 lb* / 13.6 kg	60.0 lb** / 27.2 kg

*30 lb (13.6 kg) with the weight evenly distributed across the shelf.

**The maximum weight capacity of the SMO28G-2 can be increased to 450 lb (204.1 kg) with the purchase of more shelves. For free-hanging long objects, the oven can only accommodate 2 shelves.

AIR FLOW PERFORMANCE

Ventilation Rates

Model	Cubic Feet per Minute @80°C	Liters per Minute @80°C
SMO14-2	42	1189
SMO28-2	39.4	1116
SMO28G-2	39.4	1116

Air Changes per Hour

Model	@80°C
SMO14-2	175
SMO28-2	85
SMO28G-2	85

Air Velocity Across Shelf Space

Model	Linear Feet per Minute	Meters per Minute
SMO14-2	5	1.5
SMO28-2	5	1.5
SMO28G-2	5	1.5

UNIT SPECIFICATIONS

TEMPERATURE

Range and Stability

Model	Operating Range	Stability
SMO14-2	Ambient +15 to 260°C	± 0.4°C @150°C
SMO28-2	Ambient +15 to 260°C	± 0.2°C @150°C
SMO28G-2	Ambient +15 to 260°C	± 0.2°C @150°C

Uniformity

Model	@80°C	@150°C	@260°C
SMO14-2	± 1.5°	± 3.0°	± 7.0°C
SMO28-2	± 1.5°	± 3.0°	± 7.0°C
SMO28G-2	± 1.5°	± 3.0°	± 7.0°C

Time to Temperature: From an ambient temperature of 20°C.

Model	Heat Up Time to 80°C	Heat up Time to 150°C	Heat up Time to 260°C
SMO14-2	24 minutes	35 minutes	76 minutes
SMO28-2	17 minutes	29 minutes	54 minutes
SMO28G-2	17 minutes	29 minutes	54 minutes

Recovery Time: From a 30-second door opening.

Model	Recovery to 80°C	Recovery to 150°C	Recovery to 260°C
SMO14-2	3 minutes	4.5 minutes	6.5 minutes
SMO28-2	3 minutes	4.5 minutes	5.5 minutes
SMO28G-2	3 minutes	4.5 minutes	5.5 minutes

Recovery Time: From a 60-second door opening.



Model	Recovery to 80°C	Recovery to 150°C	Recovery to 260°C
SMO14-2	5.0 minutes	7.0 minutes	12.0 minutes
SMO28-2	4.5 minutes	7.0 minutes	9.5 minutes
SMO28G-2	4.5 minutes	7.0 minutes	9.5 minutes

UNIT SPECIFICATIONS

POWER

Model	AC Voltage	Amperage	Frequency
SMO14-2	230	12	50/60 Hz
SMO28-2	230	20	50/60 Hz
SMO28G-2	230	20	50/60 Hz

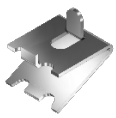
PARTS LIST

Description	Parts Number
Adjustable Feet	 2700506
Shelf Clip	 1250512
Shelf, Stainless Steel, SMO14-2 SMO28-2	 995-00006
Shelf, Wire, SMO28G-2	 6800537NCF

Ordering

Accessories and replacement parts can be ordered online at parts.sheldonmfg.com.

If the required item is not listed online, or if you require assistance in determining which part or accessory you need contact SHEL LAB by emailing parts@sheldonmfg.com or by calling 1-800-322-4897 ext. 4 or (503) 640-3000 ext. 4.

Please have the **model**, **serial**, and **part** numbers and **Part ID** of the unit ready. Tech Support needs this information to match your unit to its correct part.



SHELDON
MANUFACTURING . INC

P.O. Box 627
Cornelius, OR 97113
USA

support@sheldonmfg.com
sheldonmanufacturing.com

1-800-322-4897
(503) 640-3000
FAX: 503 640-1366